



Agromehanika

SINCE 1968



MANUAL

TRAILED TRACTOR MIST BLOWERS

AGP 1000 EN (ENU)

AGP 1500 EN (ENU)

AGP 2000 EN (ENU)

and

AGP 1000 PE

TABLE OF CONTENTS:

ES STATEMENT OF CONFORMITY 4

ES STATEMENT OF CONFORMITY 5

1 IN GENERAL..... 6

2 GENERAL SAFETY GUIDELINES AND WARNINGS 7

3 INSTRUCTIONS FOR SAFE OPERATION AND SAFETY WARNINGS..... 8

3.1 SAFETY LABELS 8

3.2 CONSIDERING THE SAFETY RULES..... 8

3.3 DANGER BE PREPARED FOR 8

3.4 UNAUTHORIZED PEOPLE 8

3.5 SAFETY WHEN HANDLING CHEMICAL AGENTS 9

3.6 EVALUATION OF DANGER SIGNS ACCORDING TO DANGER..... 10

3.7 MECHANICAL SAFETY 10

3.8 DANGER CAUSED BY LIQUIDS UNDER HIGH PRESSURE 11

3.9 WORKING PLACE OF THE OPERATOR..... 11

3.10 PERSONAL PROTECTION..... 11

3.11 BREATHING PROTECTION..... 12

3.12 SKIN PROTECTION 12

3.13 MAINTENANCE OF THE PROTECTION EQUIPMENT 13

3.14 SAFE OPERATION..... 13

3.15 SAFE MAINTENANCE 13

3.16 DRIVING ALONG ROADS AND STREETS 14

3.17 PROCEDURES IN THE CASE OF ACCIDENTS WITH CHEMICALS..... 14

3.18 RULES REGARDING TO USE OF SPRINKLING APPLIANCES..... 14

4 SAFETY WARNING LABELS ON THE MACHINE AND IN THE MANUAL 15

5 DESCRIPTION 16

5.1 SPRAYER CONSTITUENTS..... 16

5.2 TRANSPORTATION OF THE MACHINE..... 17

5.3 REGISTRATION PLATE..... 17

6 FUNCTION SCHEME 18

7 CONNECTING THE SPRAYER TO THE TRACTOR..... 19

7.1 WITH THE HELP OF ADJUSTABLE JACK..... 19

7.2 ON TRACTOR CONNECTION (TRACTION) HOOK 20

8 MOUNTING OF THE DRIVE SHAFT (CARDAN SHAFT)..... 21

8.1 OPERATOR’S SAFETY 21

8.2 CONNECTION OF THE CARDAN SHAFT 21

9 DETAILED DESCRIPTION WITH INSTRUCTIONS FOR USE..... 22

9.1	RESERVOIR	22
9.2	TANK COVER	23
9.3	ABLUTION RESERVOIR	23
9.4	RESERVOIR FOR WASHING OF HANDS	23
9.5	MIXING NOZZLE	24
9.6	THREE-WAY VALVE – EJECTOR (only AGP 1000 PE)	24
9.7	SUCTION FILTER	25
9.8	NOZZLE FOR CLEANING the main tank interior	25
9.9.	ADJUSTABLE AXLE	26
9.10	BLOWER	26
9.11	FAN WITH ADJUSTABLE VANES	27
9.12	NOZZLE BRACKETS	28
10	VALVE ADJUSTMENTS	29
10.1	MIST BLOWER AGP 1000 PE	29
10.2	MIST BLOWER AGP 1000 EN, AGP 1500 EN, AGP 2000 EN	30
11	OPTIONAL EQUIPMENT	31
11.1	SURFACE CLEANING SET	31
11.2	STRAINER FLUSHER	32
11.3	PACKAGING AND STRAINER FLUSHER	32
11.4	SUCTION BASKET WITH SUCTION TUBE	33
11.5	LONG RANGE SPRAYING NOZZLE BRACKET	34
11.6	ADJUSTABLE NOZZLE DEFLECTOR	34
11.7	TERRACE SPRAYING KIT	35
11.8	SIGNAL LIGHTS	35
12	PRESSURE REGULATOR	36
12.1	PRESSURE REGULATOR M170	36
12.2	PRESSURE REGULATOR PR8	36
12.3	PR9 PRESSURE REGULATOR	37
12.4	REGULATOR LABELLING	38
12.5	MAIN COMPONENTS OF THE PRESSURE REGULATOR	38
12.6	REGULATOR OPERATION ADJUSTMENT	41
12.7	PRESSURE REGULATOR MAINTENANCE	42
13	PUMP	42
13.1	CHECK BEFORE USING THE APPLIANCE	42
13.2	USE	43
13.3	AFTER USE	43
13.4	TECHNICAL DATA	43
13.5	PUMP MAINTENANCE	43
14	CLEANING THE MACHINE	45
15	MAINTENANCE AND STORAGE AFTER SPRAYING SEASON	46
15.1	TUBES	46

15.2 COLOUR	46
15.3 TANK	46
15.4 PRESSURE REGULATOR	46
15.5 TUBE JOINTS	46
15.6 SCREWS	47
15.7 OTHER PARTS	47
15.8 PROTECTION AGAINST FREEZING	47
15.9 PUMP	47
15.10 DRIVE/TRANSMISSION SHAFT	47
16 POSSIBLE ERRORS	48
17 TECHNICAL DATA	49
17.1 MIST BLOWERS WITH STANDARD FAN HOUSING	49
17.2 MIST BLOWERS WITH AIR DEFLECTOR	50
17.3 MULTIPLIER:	50
17.4 TECHNICAL RESIDUE	51
17.5 LABELLING:	51
17.6 MATERIALS AND RECYCLING	51
17.7 MACHINE DISPOSAL	51
18 COMBINATION MATRIX	52
19 GENERAL INSTRUCTIONS FOR SPRINKLING	53
19.1 PREPARATION BEFORE STARTING OPERATION	53
19.2 CONNECTOR FOR PUMP FLOW CONTROL MEASUREMENT	53
19.3 NOZZLE FLOW RATE CONTROL MEASUREMENT	53
20 TYPES OF NOZZLE INSERTS	54
20.1 CHARTS	54
20.2 DIFFERENT CALCULATIONS	55
20.3 SOME RECOMMENDATIONS	56
NOTES	57

ES STATEMENT OF CONFORMITY

Manufacturer:

AGROMEHANIKA, proizvodnja in trgovina Kranj d.d.
Hrastje 52 a, KRANJ, SLOVENIJA

declares that the products:

SPRAYER AGP 1000 EN (ENU)
SPRAYER AGP 1500 EN (ENU)
SPRAYER AGP 2000 EN (ENU)

is manufactured in accordance with:

1. **Directive on Machinery 2006/42/EC;**
2. **Directive 2009/127/EC amending Directive 2006/42/EC with regard to machinery for pesticide application;**
3. **Rules on the requirements for the correct operation of equipment for the application of plant protection products, and on the conditions and method for inspections of such equipment (Official Gazette of The Republic of Slovenia, no.101/2013)**

The following harmonized European standards on safety were applied:

SIST EN ISO 4254-1:2013 – Agricultural machinery – Safety – Part 1: General requirements;

SIST EN ISO 4254-6:2010 – Agricultural machinery – Safety – Part 6: Sprayers and devices for distributing liquid fertilizers (ISO 4254-6:2009);

SIST EN ISO 4254-6:2010/ AC:2011 – Correction AC:2011 to standard SIST EN ISO 4254-6:2010;

SIST EN ISO 12100:2011 – Machine safety – General principles of planning – Risk assessment and risk reduction (ISO 12100:2010);

[SIST EN ISO 13857:2008](#) – Machine safety – Safe distances, preventing reach of dangerous areas with upper or lower limbs.

Kranj, 04.09.2016

Production Manager:
 (*Responsible for Technical
 Documentation*)

Matjaž Kuhar, dipl.ing.



Director:
 Jan Šinkovec



ES STATEMENT OF CONFORMITY

Manufacturer:

AGROMEHANIKA, proizvodnja in trgovina Kranj d.d.
Hrastje 52 a, KRANJ, SLOVENIJA

declares that the products:

SPRAYER AGP 1000 PE

is manufactured in accordance with:

- 1. Directive on Machinery 2006/42/EC;**
- 2. Directive 2009/127/EC amending Directive 2006/42/EC with regard to machinery for pesticide application;**
- 3. Rules on the requirements for the correct operation of equipment for the application of plant protection products, and on the conditions and method for inspections of such equipment (Official Gazette of the Republic of Slovenia, no. 101/2013)**

The following harmonized European standards on safety were applied:

SIST EN ISO 4254-1:2013 – Agricultural machinery – Safety – Part 1: General requirements;

SIST EN ISO 4254-6:2010 – Agricultural machinery – Safety – Part 6: Sprayers and devices for distributing liquid fertilizers (ISO 4254-6:2009);

SIST EN ISO 4254-6:2010/ AC:2011 – Correction AC:2011 to standard SIST EN ISO 4254-6:2010;

SIST EN ISO 12100:2011 – Machine safety – General principles of planning – Risk assessment and risk reduction (ISO 12100:2010);

SIST EN ISO 13857:2008 – Machine safety – Safe distances, preventing reach of dangerous areas with upper or lower limbs.

Kranj, 04.09.2016

Production Manager:
(Responsible for Technical
Documentation)

Matjaž Kuhar, dipl.ing.



Director:
Jan Šinkovec



Dear customer,

We would like to thank you for your trust, which you have shown by buying the sprayers appliance for chemical plant protection of the company AGROMEHANIKA. The reliability and efficiency of the appliance depends on how you will take care of the appliance. We advise you to read and consider this instruction manual carefully before connecting the appliance to the tractor. This manual contains essential information for efficient use and a long durability of the appliance.

1 IN GENERAL

The sprayers AGP 1000EN(U), AGP 1500EN(U), AGP 2000 EN(U) and AGP 1000 PE are machines of modern concept and design, equipped in accordance with the latest technical and safety requirements for this type of machines. They are designed and constructed for applying chemical agents dissolved in water solution which are normally used for chemical protection of agriculture crops in fruit-growing and viticulture.

Chassis is of robust construction which together with a low barycentre enables working on a more challenging terrain as well.

Flexible coupling enables sprayer wheels to follow tractor wheels, but also an easy turning and a small turning circle.

Sprayer consists of:

- Supporting chassis
- Main tank with pouring strainer
- Additional tanks for flushing and washing hands
- Pump
- Pressure and flow regulator
- Suction filter
- Pressure filter
- Three-way valve
- Mixing nozzle
- Fan, and
- Membrane nozzle brackets with ceramic nozzle inserts.

Tanks falling within the scope of the machine are made from chemical heavy-duty PE-HD (high-density polyethylene), which provides them with a constant shape stability. The walls in their interiors are very smooth, which makes the cleaning after spraying more convenient.

Its construction design enables an easy accessibility to vital elements of the sprayer and an easy handling with the sprayer. A robust construction, quality constituent elements and plenty of additional equipment enable the user a reliable operation as well as an optimal use of spray agents and supplied energy.

Air capacity is variable due to the variable fan, which enables protection of both new and older plantations. Adjustable fan, quality nozzle inserts, and plenty of optional equipment enable an optimal consumption of energy and of protective agents.

The blower with adjustable fan is incorporated in the rear part of the sprayer. Adjustable fan enables adjustment of speed and air amount to the type of plantation and lushness of vegetation. Fan drive is performed by a single-stage multiplier with a possibility of shut-down (neutral gear).

A standard blower version is of steel construction and does not comprise an air rectifier that belongs to optional equipment. The rectifier evenly distributes the air to the left, to the right, and to the whole height of the habitus.

The following sections will describe in more detail main sprayer constituents and handling with them.

















The manual for use covers more sprayer models; therefore consider only chapters that apply to your type of the machine.

Do not use your sprayer for pumping or sprinkling of:

- water solutions with a higher specific weight and viscosity than water;
- chemical solutions which should not come in contact with some of the parts of the sprayer;
- drinking water;
- sea water and other salty solutions;

- water which temperature is higher than 40 °C or lower than 5 °C;
- all kinds of lacquer or varnish;
- fast dissolving diluents;
- oil or grease;
- liquids that contain granulates or hard swimming parts.

2 GENERAL SAFETY GUIDELINES AND WARNINGS

	This sign indicates a warning or important instruction. As it concerns the safety of the user, follow the instructions and recommendations bearing this sign!
	Read the “User Manual” carefully before operating the machine. It is important that all the personnel using the machine are familiar with this “User Manual”!
	The national legislation may require registration (certification) of personnel operating the machine and persons who are allowed to operate machines for chemical protection therefore you must ensure your compliance with the law!
	Before using chemical agents, perform a pressure test on the machine by using clean water!
	When operating the machine which is not fitted with a fully enclosed cab, always use protective clothing, gloves and mask!
	Clean and wash the machine after each use and before any maintenance or testing procedures!
	Never perform maintenance and repairs when the machine is in operation!
	After maintenance, immediately reinstall all safety devices on the machine!
	Before welding or repairing the machine, disconnect all connections to the machine. Before that, remove all flammable and explosive substances from the area surrounding the machine.
	Never eat, drink or smoke during spraying, i.e. handling harmful substances and contaminated equipment!
	After spraying, always change the work clothes and wash your hands thoroughly!
	After each use, clean and wash all the tools used during spraying.
	In the event of poisoning, immediately seek medical attention and show the packaging of protective agents used!
	When the machine is in operation, do not allow children or animals come near the machine!
	It is prohibited to pour or release the spray residue in the environment.
	Avoid spraying during strong wind!
	If any part of the instructions is unclear, please contact a representative or the manufacturer of the machine, who will provide you with further instructions and explanations regarding the proper use of the machine.

3 INSTRUCTIONS FOR SAFE OPERATION AND SAFETY WARNINGS

3.1 SAFETY LABELS



The sign on the left is a safety-alert symbol and is normally placed on the machine together with other labels. Comply with the instructions for safety, also in responding to emergency cases.

3.2 CONSIDERING THE SAFETY RULES



Read the instructions considering the safety rules in the operation manual of your machine very carefully. Make sure that the labels on the machine are in good condition and can be well seen. After repairing the machine or replacement of any spare part make sure that all of the labels are fitted on the appliance. Spare labels are available at your authorized seller of the appliances. Learn how your machine is working and how to handle it and its control units.



DO NOT ALLOW UNAUTHORIZED PEOPLE TO USE THE MACHINE!

Make sure that your machine is always in good working condition. Each unauthorized change on the machine can weaken the functionality and/or the safe operation and/or shorten the durability period of the appliance.

3.3 DANGER BE PREPARED FOR

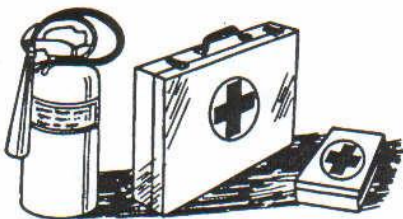

Be prepared for a sudden fire. Make sure that there is always a first aid kit and a fire extinguisher available while you work. Make sure that the telephone numbers of your personal physician, ambulance, hospital and fire brigade is always kept on a good seen place.

3.4 UNAUTHORIZED PEOPLE

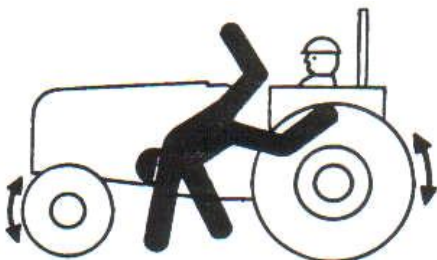

Every unauthorized person who is seating, standing or in any other way driving on the tractor can get hurt (he or she can fall of the tractor or get hurt by the means of the tractor). The person driving on the tractor can have influence on the driver who is operating the tractor or change its centre of gravity. The unauthorized person on the tractor can have influence on driver's sight and can be held responsible for unreliable working conditions on the tractor. Do not allow unauthorized people to be in the immediate vicinity of the machine.



IT IS FORBIDDEN FOR UNAUTHORIZED PERSONS TO RIDE ON THE TRACTOR!

3.5 SAFETY WHEN HANDLING CHEMICAL AGENTS



Be very careful when handling chemical agents and in this way avoid possible injuries or damages done as to you as well as to the environment:

- Be very careful when handling chemical agents. Make sure that you do not come in direct contact with the chemical agents. Chemical agents must be handled in the same way as poison.
- Choose such chemical agents that are the least harmful to your health, the most efficient and easy soluble.
- Always read the instructions for use which are printed on the packaging of the chemical agents. Consider all of the rules and safety instructions, and use the instructions.
- While working always use protection devices for the respiratory organs, such as a breathing mask or a helmet with fresh air.
- Wear appropriate clothes while preparing the chemical agents. Use protection goggles, gloves, boots and protection clothes. Pay attention to your protection equipment. Do not use “worn” protection.
- Make sure that your protection equipment and clothing are in good condition. Dirty gasmasks can cause allergic reactions to the skin. Change the filter regularly!
- Choose “safer” chemical agents. Pay special attention to chemical agents which are not that dusty or do not cause allergic reactions to the skin.
- When choosing chemical agents pay special attention to those which are packed in a “safer” way.
- The preparing of chemical agents should never take place in closed rooms. When preparing chemical agents turn off the machine and in this way lower the risk of spilling the chemical agent.
- The chemical agents should be prepared only in still weather or in a calm place.
- Make sure that your machine is regularly cleaned, since you can in this way lower the chance of a direct contact with the chemicals.
- For preparing and mixing of the chemical agents only tools for this purpose should be used: measuring scale, measuring tools, funnel, bucket. Make sure that the tools are cleaned regularly.
- Do not prepare more of the chemical agents than needed.
- Make sure that your working day in which you are using chemical agents is no longer than 8 hours. Avoid stress and heavy manual work.
- Before sprinkling and 8 hours after sprinkling it is recommended not to consume alcohol.
- Do not eat, drink or smoke while working with chemical agents.
- Do not try to clean blocked nozzles with blowing (by means of your mouth).
- Consider the abstinence of the insecticide in the sprinkling period.
- Immediately wash out your eyes with water if the chemical comes in contact with them.
- After sprinkling, wash your face and hands thoroughly before eating or drinking.
- Make sure that children and animals cannot get to the machine until this one was thoroughly cleaned.
- Clean the machine after using it, put it in an appropriate place and make sure that unauthorized people do not have access to it.
- After using chemical agents wash yourself thoroughly.
- Clean and wash the machine after every single use and before any maintenance work.

- In case you have a certain medical problem in the time while using the chemical agents, consult your personal physician and try to contact the selling agent who is responsible for your chemical agents.
- If you have an accident which involves a chemical agent, we advise you to do the following:
 - o eyes and skin: wash with plenty of fresh water;
 - o throat and gullet: drink loads of water (no milk!);
 - o lungs: fresh air.

3.6 EVALUATION OF DANGER SIGNS ACCORDING TO DANGER

Each chemical agent has a danger sign printed on the packaging which conveys the degree of danger. If possible, avoid chemical agents which have a skull printed on the packaging or include other signs which say that certain chemical agents have an etching effect. Even if a packaging does not include signs of danger that does not mean that the chemical agents is not harmful or dangerous. Although you are using insecticides that have none of the danger signs printed on the packaging we advise you to handle them with extreme care, since they can be harmful to your health in the long term.

Danger signs which can be seen on packaging of chemical agents:

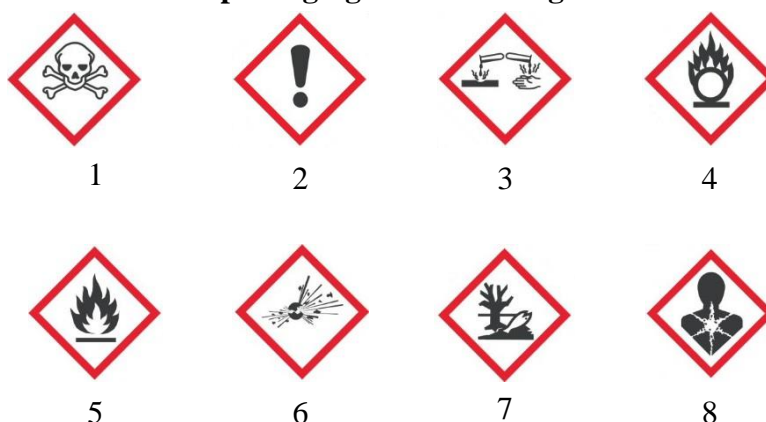

- 1- acute toxicity;
- 2- acute toxicity, skin and respiratory irritation;
- 3- corrosive;
- 4- oxidising;
- 5- flammable;
- 6- explosive;
- 7- hazardous to the environment;
- 8- mutagenic, carcinogenic, toxic; hazardous to specific organs.

3.7 MECHANICAL SAFETY



- Do not touch the machine between working!
- Do not remove safety labels or any other safety equipment of the machine!
- Do not exceed the recommended air pressure in the tyres!
- Maintain the tyres regularly!
- If you want to use the machine in the public traffic you must fit it with lights and other illuminates in accordance with the traffic regulations.
- Do not enter the reservoir in the time of preparing of the chemical agents or cleaning of the reservoir!
- Never set the working pressure higher than 15 bar (maximum allowable pressure on the sprayer);
- Do not start working until you are sure that there are no unauthorized people in the near of the machine!
- Pull out the key from the key-lock after you have finished working and in this way prevent a sudden start of the machine.

3.8 DANGER CAUSED BY LIQUIDS UNDER HIGH PRESSURE



- The liquid which leaks from the pipes can be under high pressure and can cause injuries to your skin, even more; it can cause dangerous injuries if the liquid spreads under your skin.
- Never try to dismount a hydraulic pipe or any other of the hydraulic installation as long as this one is under high pressure. Before you start up the hydraulic system make sure that the installation is safe.
- Help yourself with a piece of cardboard when trying to find the place of leakage. Protect your hands and body by means of gloves and protective clothing if you are handling a high pressure hydraulic system.
- In the case of injury immediately call your personal physician. Each penetration through the skin must be stopped; the liquid must be removed within few hours.

3.9 WORKING PLACE OF THE OPERATOR

- There is only one person needed for operation the machine. This person does not need an assistant. The operator of the sprayer is also the driver of the tractor.
- This machine can be operated by a person who is older than 18 years and has the needed know-how that is needed for a safe and accurate operation of sprinkling appliances.
- The person needs to be in good health – mentally and physically.
- Operational work and maintaining of the sprayer can be only carried out by authorized personal that has the needed know-how for this type of work.
- The operator of the sprayer must have a medical certificate (in accordance with local regulations).
- The working place of the operator: 1 meter around the machine and tractor.
- While sprinkling keep the windows and doors of the tractor closed. It is recommended that the operator has a hermetically closed cabin which allows the operator to create overpressure with aeration of fresh air that disables chemically polluted air to enter the cabin.
- While sprinkling, it is recommended that the operator stays in the cabin for about 90-95% of the time, so the chemical agents cannot have influence on his or hers health. Should the operator notice a change in the working of his or hers organs or feel dizzy, he or she should immediately put on the protection breathing mask. However, the best thing to do is to leave the field and look for shelter in a cleaner area.



3.10 PERSONAL PROTECTION

- The operator is advised to use well buttoned clothing and efficient protection equipment while working.
- The operator can come in contact with chemicals through his or her skin, mouth or nose. If you do not work safely even the best protection equipment cannot be any use to you.
- A safe working with sprayers requires full attention of the operator, so listening to music (per headphones) while working is not recommended.

3.11 BREATHING PROTECTION

There are many different types of filters available that can protect you against inhaling chemicals.

- It is recommended to use masks that protect the whole face and are fitted with combinations of different filters (filter for gas-smoke). An even more efficient protection can be achieved by means of a protection helmet in which overpressure can be created.



- Make sure that you are using an appropriate filter:
 - A (brown): can be used for most organic chemicals;
 - B (grey): can be used for most inorganic chemicals;
 - P (white): can be used only for liquid or powder chemicals;
 - Combination of a brown/white filter with the mark A2P2 in the European Union can be used for most organic

chemicals. The mark A2P2 refers to a combination of filters which provide appropriate protection against most gases and vapours that are created by using liquid or powder chemicals. A2 refers to protection class II which means that you can use the filter until it reaches a concentration of 0.5 volume-percentages. P2 refers to gas protection class II.

- The combination B (grey/white) filter must be used in the case of handling inorganic chemicals.
- Before using the mask check the tightness and sealing of it. Check the mask for damages and make sure that the outer valve is clean and can be closed without any problems.
- Write down the date of the last usage of the filter. The A2P2 filter must be replaced once a month nevertheless how many times it was used. Filter B must be replaced after every single use! The filter must be used within 6 months after the packaging of the filter was opened. Make sure that used filters are destroyed in accordance with local regulations.
- Never check the efficiency of the filter by smelling:
 - certain poisonous elements are odourless,
 - the concentration of the poison cannot be always noticed by human nose,
 - smelling of certain elements can damage the nasal mucous membrane.
- Always check the expiring date of the filter.



WARNING: To avoid inhalation and prevent chemicals from entering through your mouth, never smoke, eat or drink when handling them!

3.12 SKIN PROTECTION

It is recommended to wear the following clothes in order to protect your skin:

- Rubber gloves in order to protect your hands which must be long enough. If the gloves are worn they need to be replaced. Change the gloves after every fifth use. Powder the inside of the gloves.
- Rubber or neoprene boots that are resistant to water and chemicals.
- Overalls that are resistant to water and chemicals and are fitted with a hood. The overall must cover the ends of gloves and boots.
- A waterproof apron for protection of your clothes; in a good protected tractor cabin the apron can be removed.
- A mask that protects the whole face.

Make sure that all of your clothes are well cleaned after every use. Never perform sprinkling when your clothes are wet, since it can cause a strong contact with your skin. Be very careful in the case your skin gets injured. After handling chemicals always wash your hands with soap and loads of water. After you have finished working also wash your face.

3.13 MAINTENANCE OF THE PROTECTION EQUIPMENT

After every single use thoroughly clean your protection equipment. Wash the mask, boots, gloves and working overall with mild soap water and let them dry.

Store your protection equipment in a dry, cold and clean room. Never store your protection equipment in the same room as the chemicals.

Store your protection clothes apart from other clothes.

Protection equipment that gets dirty between handling chemicals must be cleaned in accordance with regulations on cleaning of dangerous materials.

3.14 SAFE OPERATION

Before starting working the operator must check the correct and safe operation of the machine.

- It is not allowed to sprinkle in foggy and/or rainy weather or when the wind speed exceeds 4 m/s. The direction of sprinkling must be adjusted to the wind direction.
- If there are two tractors with sprinkling appliances working simultaneously, they must not pollute each other's working area atmosphere. In order to protect your health pay attention to the wind direction and speed.
- Never bring personal things in the area of sprinkling or when handling chemicals. Before every meal thoroughly clean your hands and face and wash out your mouth with fresh water.
- Before filling in the chemicals check the functioning of the machine by filling the reservoir with clean water.
- The sprayer pump receives the power from the connecting shaft of the tractor by means of the cardan shaft. All of the driving parts can cause bad injuries so in order to avoid that please follow the instructions below:
 - To drive the pump only such a cardan shaft must be used which characteristics are in accordance with the recommendations of the manufacturer and which is fitted with a protection cover.
 - Connect the machine to the tractor only if the drive shaft (P.T.O.) is turned off.
 - Connecting and disconnecting of the cardan shaft must be performed only when the engine is shut off.
 - Before you load the drive shaft (P.T.O.) check the rpm of the engine and make sure that there are no people or animals in the danger area of the machine.
 - The cardan shaft should be cleaned and greased only when the drive shaft (P.T.O.) is turned off, the engine shut down and the start key out of the key-lock.
 - Do not turn on the drive shaft of the tractor (P.T.O.) without a reason and check if the difference between the universal-joint angles is not too big.



Warning! Do not turn on the driving shaft of the tractor (P.T.O.) while the tractor's engine is not running!

3.15 SAFE MAINTENANCE

- Before starting to operate the machine learn how to maintain it. Keep the working place clean and dry.
- Do not grease, maintain or adjust the machine while this is moving! Do not touch moving parts of the machine! Turn off the machine and make sure that there is no working pressure in the circulation of the chemicals!
- Do not maintain or service the machine before this was thoroughly cleaned.
- During maintenance and servicing of the machine turn off the electrical charging by turning the start key or disconnecting the connections.
- Disconnect the drive shaft of the tractor (P.T.O.) in order to avoid a sudden start of the sprayer.
- Do not perform inspections of the machine without turning on the machine's "safety" devices.
- Do not perform welding of the machine if you have used ammonium nitrate or any other liquid that contains ammonium nitrate for sprinkling without having thoroughly cleaned the machine before.

- Do not enter the reservoir to repair or clean it.
- Support and safely mount all parts that need to be lifted during maintenance.
- Keep all of the sprayer's parts in good condition. Repair eventual damages immediately. Replace worn and damaged parts. Remove excess oil, grease or any other debris.
- Disconnect the battery before you start to adjust the electrical system or perform welding on the machine.
- During maintenance of the machine or cleaning the nozzles use appropriate protection equipment in accordance with the regulations.
- It is strictly forbidden to release chemicals into the environment.

3.16 DRIVING ALONG ROADS AND STREETS

Do not drive around with your sprayer attached to the tractor. If this cannot be avoided please consider the following:

- Drive along roads and streets with your sprayer attached to the tractor only when there are no chemical agents in the reservoir. The maximum tractor speed with a full reservoir of water must not exceed 15 km/h.
- Connect the sprayer to the tractor only if the load on the wheels does not exceed the prescribed maximal load. After connecting the sprayer to the tractor at least 25% of weight must be on front wheels. You can achieve these values by adding weights at the front and removing weights at the back of the tractor. Find out how many weights need to be added or removed by means of weighing the tractor before the first use of the sprayer.
- In the case the sprayer completely or partially covers the lights and signs at the back of the tractor you will have to attach some additional lights and signs onto the sprayer.
- Follow the traffic regulations when driving along roads and streets with your sprayer attached to the tractor.
- Keep the garniture on an appropriate height when driving along roads and streets. In the upper position secure the 3-point suspension of the tractor in order to avoid a sudden fall or slip of the sprayer.

3.17 PROCEDURES IN THE CASE OF ACCIDENTS WITH CHEMICALS

In the case your skin or eyes come in contact with chemicals or their solution, wash them out with plenty of water and repeat the process several times. In the case of suspecting poisoning (symptoms: sweating, dizziness, depression, headache, sickness):

- immediately stop working;
- take off wet clothes;
- remain calm;
- if you feel sick because of consumption of chemicals try to throw up;
- lay on your side;
- immediately call for medical help and let the physician see the label of the chemical agent, so he or she will easier be able to determine the kind of poisoning.

In the case of suspecting poisoning the patient must not eat or drink castor oil, milk, butter, eggs and alcohol, since these ingredients worsen the poisoning effect.

3.18 RULES REGARDING TO USE OF SPRINKLING APPLIANCES

The operator and user of the sprayer must be familiar with rules regarding plant protection.

4 SAFETY WARNING LABELS ON THE MACHINE AND IN THE MANUAL

You can find certain safety and warning signs in this instruction manual that are also attached to the machine. Take a closer look at them in order to work safely. Follow the instructions and advice concerning precautions listed below. Make sure that the labels on the machine are in good condition and can be well seen. After repairing the machine or replacement of any spare part make sure that all of the labels are fitted on the appliance. Spare labels are available at your authorized seller of the appliances.

	Product conforms with the safety requirements or standards		Use protection overalls while working.
	Warning: read the instruction manual before connecting the appliance to the tractor for the first time!		If the cabin of the tractor is not constructed in an appropriate way, use your gas mask while working.
	Warning: sign that indicates the possibility of personal injuries or damages of the machine!		Use ear protectors while working.
	Rotating direction and number of revolutions of power take-off (PTO)		Speed limit
	Warning: maximal rpm and the direction of the driven shaft!		Warning: maximal allowed pressure in the sprinkling appliance (20 bar)!
	Warning: keep away from rotating drive shafts!		Entrance forbidden area – machine in operation
	Warning: presence of poisonous chemical agents!		It is not allowed to remove any of the safety devices from the machine!
	Flying parts hazard!		It is not allowed to clean, grease or maintain the appliance as long as it is running!
	Danger! Keep safety distance!		It is not allowed to smoke while operating the appliance!
	Follow the instructions for use!		It is not allowed to enter the reservoir!
	Use protective gloves while working.		Water for washing of hands. Warning: this water is not drinkable!

5 DESCRIPTION

Sprayers, to which this manual applies, are of modern concept, with polyethylene tanks, rounded edges, smooth interior walls and inclined bottoms. The sprayer construction ensures a short barycentre distance between the tractor and machine, a well-stirred spray agent mixture, a complete emptying of the tank, and a simple cleaning process.

The fan, located on the rear side of the sprayer, directs the air to the left, to the right and to the whole height of the habitus. Due to the prolonged distance of drops through the habitus, the airflow is directed diagonally to the row. Hence, the drift of the protective agent towards the tractor is reduced to the minimum.

The fan with adjustable vanes enables the user to adjust the speed and amount of air to the type of plantation and to the lushness of vegetation.

5.1 SPRAYER CONSTITUENTS

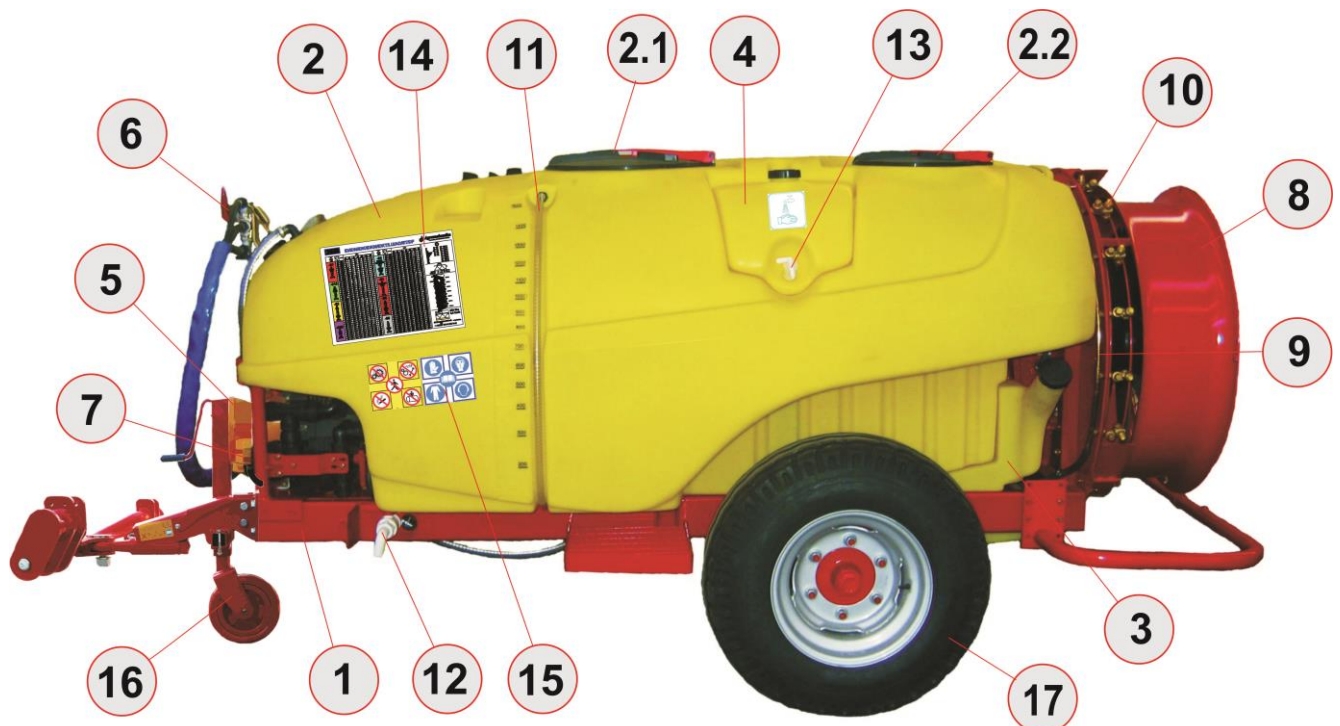

- | | |
|--|--|
| 1. Chassis | 9. Spraying arc (left-right) |
| 2. Main tank | 10. Nozzle bracket with nozzle inserts |
| 2.1 Tank lid – main | 11. Litre scale – level indicator |
| 2.2 Tank lid – small | 12. Valve for main tank emptying |
| 3. Flushing tank | 13. Pipe for washing hands |
| 4. Tank for washing hands | 14. Nozzle consumption chart |
| 5. Pump | 15. Safety warning labels |
| 6. Pressure regulator | 16. Supporting wheel (jockey wheel) |
| 7. Suction filter with regulation valves | 17. Rim with tyre |
| 8. Case with fan | |

Rather than having a standard version of a round-shaped sprayer blower, the sprayer can be equipped with a rectifier of a lower/higher version, whose main advantage is a more even distribution of air amount and airflow to the left and to the right (ENU mark).

The following sections will describe in more detail main sprayer constituents and handling with them; the second part of this manual, however, encompasses a spare parts catalogue.

The manual covers more sprayer models; therefore consider only chapters that apply to your machine.

5.2 TRANSPORTATION OF THE MACHINE

During transport and if the sprayer is loaded or unloaded from the lorry, make use of the fastening points of the standard three-point system on the sprayer or, if you are using a forklift, the lower part of the supporting framework.

5.3 REGISTRATION PLATE

MACHINE REGISTRATION PLATE

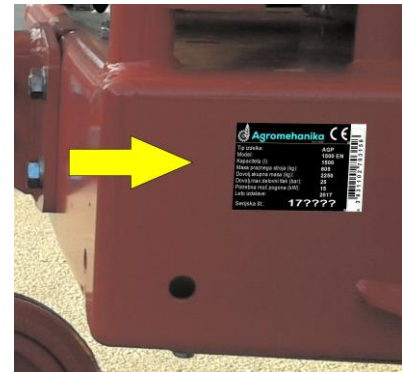

It is affixed on the front side of the sprayer and contains the following important data:

- address of the manufacturer and the country of origin
- type of the product
- model
- nominal capacity
- unladen machine mass
- maximum authorised mass
- maximum allowable operating pressure
- required drive power
- year of manufacture,
- serial number and
- EAN identification number.
- Apart from technical data, there are also CE and SVN signs on the registration plate. The CE sign identifies that the machine complies with safety requirements and standards; whereas the SVN sign with the year of issue identifies that the machine is in accordance with the requirements about certifying machines for application of phytopharmaceutical agents.

PUMP REGISTRATION PLATE

It is affixed in a clearly visible position and contains:



- address of the manufacturer and the country of origin
- pump type
- nominal flow rate
- maximum flow rate at maximum allowable rotating speed and maximum allowable operating pressure
- required drive power
- type of pump lubricant, and
- serial number of the pump.

The registration plate shape in the picture may deviate from the actual state, depending on the type of the pump incorporated in the sprayer.



When ordering spare parts from a dealer, please specify all the data indicated on the registration plate.

6 FUNCTION SCHEME

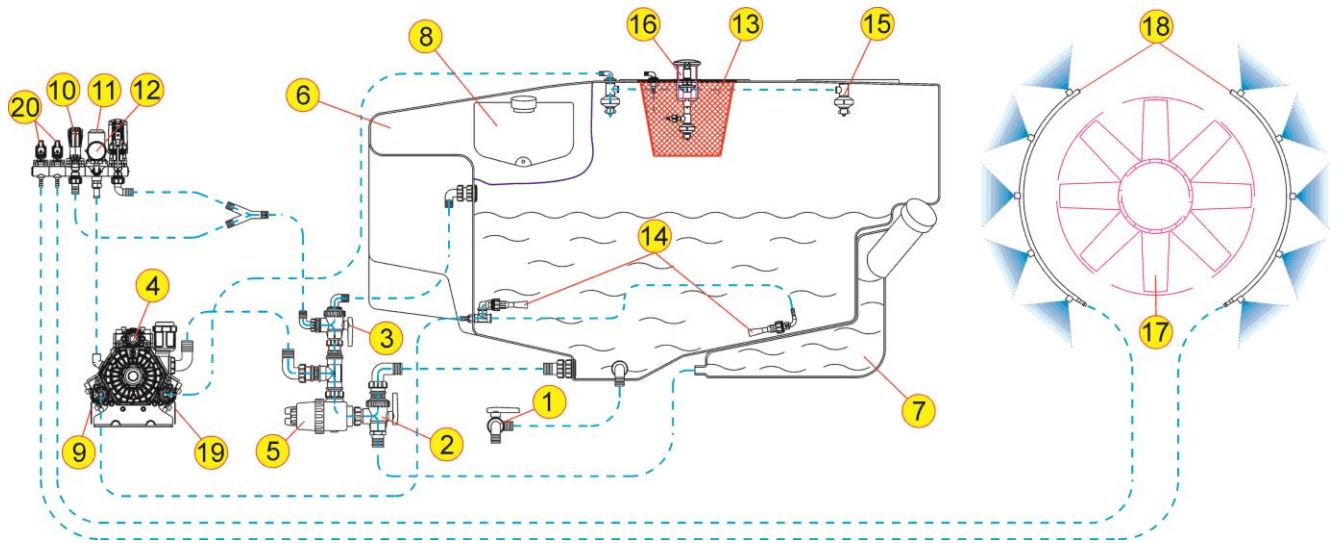

1. Outlet valve
2. Three-way selector valve
3. Selector valve
4. Pump
5. Suction filter with valve
6. Main tank
7. Flushing tank
8. Clean water tank for washing hands
9. Valve for opening of separate spraying sections
10. Pressure regulator with regulation valve
11. Pressure filter
12. Pressure gauge (manometer)
13. Strainer – pouring sieve
14. Mixing nozzle
15. Nozzle for tank flushing
16. Packaging and strainer flusher (additional equipment)
17. Fan
18. Spraying arc (tube) with nozzles
19. Valve of the nozzle for tank flushing
20. Valve for opening the spraying section.

7 CONNECTING THE SPRAYER TO THE TRACTOR

All pull-type sprayers are designed for connecting to the tractor three-point system of I. or II. categories (diameter of clamp bolts 22 or 28 mm).

7.1 WITH THE HELP OF ADJUSTABLE JACK

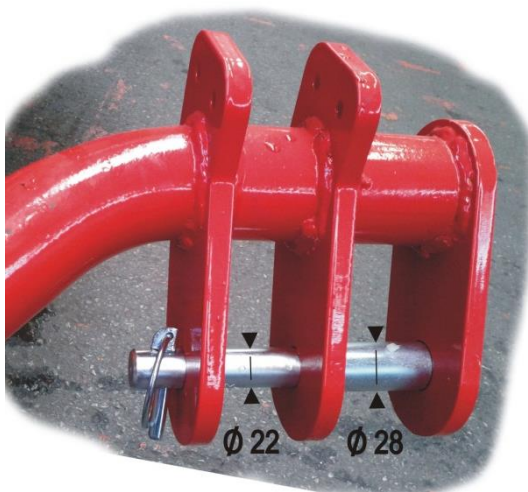

Shape and position of connector on the sprayer enable hitching of the machine to the tractor in more ways – with both standard lift arms with eye connectors and newer automatic lift arms. In the first case, to perform the hitching, you must pull out the clamp bolt and set the tractor lift arms to the place designed for the applied clamping category. After setting the clamp bolts through the eye of left and right lift arms, push the bolts back to their place and secure them with an enclosed pin to prevent them from falling off.

If the tractor is equipped with automatic clamping hooks, clamp bolts need not be pulled out, only the required connection size must be chosen for clamping.



Lift arms with eye connector



Automatic clamping hook

7.2 ON TRACTOR CONNECTION (TRACTION) HOOK

If the sprayer traction jack must be pulled out fully, **never hitch the sprayer** on the tractor bottom lift arms, but use the connection (traction) hook on the rear part of the tractor instead.

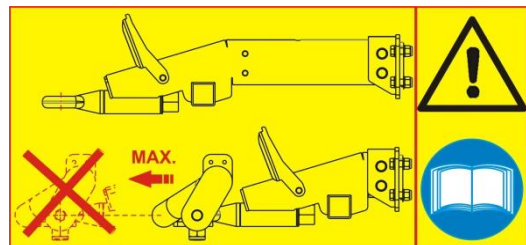
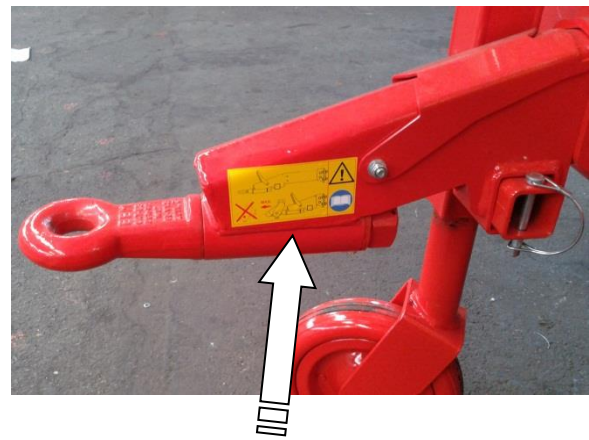

After installing the sprayer, raise the two lift arms to the operating height or until the sprayer's chassis is positioned more or less horizontally (the front and rear of the sprayer are equally distanced from the ground) and fasten them with side tension devices to prevent sideward oscillation of the sprayer.

Afterwards, connect the pump shaft of the sprayer to the tractor's PTO drive shaft with a shaft coupling. Make sure you only use the PTO drive shaft of the tractor with a lower number of revolutions (540 rpm) to prevent damage to the pump.



General recommendation for safe hitching of the sprayer:

- Check if the pressure in the tyres of the tractor (see tractor manual) and the sprayer is adequate and refill it if necessary.
- Make sure that the pressure regulator never hits the tractor cabin or any other part of the tractor.
- If necessary, place the front weight on the tractor (see tractor manual).
- When the sprayer tank is full, drive slowly (impact on the fracture will be lesser).

8 MOUNTING OF THE DRIVE SHAFT (CARDAN SHAFT)

8.1 OPERATOR'S SAFETY



To avoid possible accidents and personal injuries please follow the instructions and recommendations written below!

- Before mounting (connecting of the cardan shaft to the tractor and the sprayer) the drive shaft – cardan shaft, **always turn off the engine and remove the start key from its lock.**
- When mounting the cardan shaft, the cardan shaft of the tractor can be easily turned if the engine and the cardan shaft are turned off.
- When mounting the cardan shaft make sure that the safety pin is in right position and well stuck in its hole. Pull and push the cardan shaft forwards and backwards as long as the safety pin is not in its hole.
- Rotating shafts can be very dangerous!
- Always make sure that all of the safety devices are on their place and that all of the rotating surfaces are well covered, including the “junctions” of the cardan shaft on both ends! Do not use cardan shafts without having secured them!
- Do not touch rotating cardan shafts! The safety distance to a rotating cardan should not be less than 1.5 m.
- Before starting the engine, secure PTO protective elements with a chainlet.
- Make sure that the protection of the cardan on the tractor is well connected (attached)!
- Always turn off the engine and remove the start key from its lock before starting maintaining the machine or connecting the cardan shaft!

8.2 CONNECTION OF THE CARDAN SHAFT

The first mounting of the cardan shaft should be performed as follows:

1. Mount the sprayer to the tractor and lift the tractor's lift arms to such a height, where the distance between the tractor's connection shaft and the sprayer's connection shaft is the **shortest (both connection shafts are on the same height)**. Be careful not to hit the sprayer against the tractor or the ground.
2. Stop the tractor's engine and remove the start key from its lock).

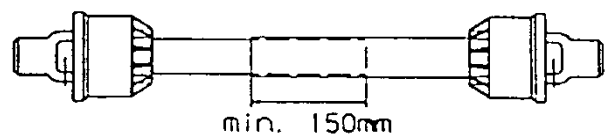
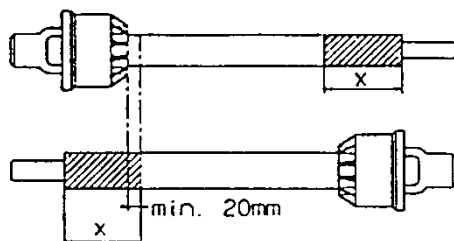

- 3 Connect the short exiting cardan shaft of the tractor with the short cardan shaft of the sprayer by means of the cardan shaft.
- 4 In the case the cardan shaft is too long and needs to be shortened, pull out the cardan shaft and mount each end of it separately to the shaft of the tractor and to the shaft of the sprayer, measure it out and mark the place where it needs to be cut.



WARNING: the covering of both cardan shafts must be at least 150 mm.

5. Use an appropriate tool to shorten both parts in the same way and do not forget to remove the swarf.
6. Attach the profiles and join the parts

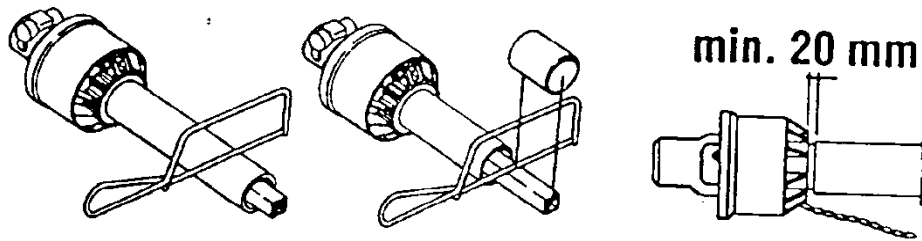

7. Mount the cardan shaft to the tractor and the sprayer.

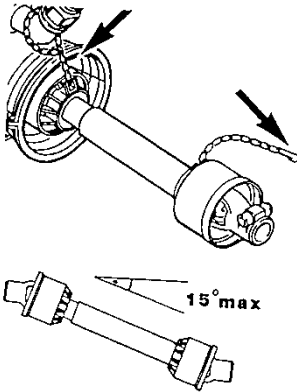

WARNING: Always mount the female end of the cardan shaft to the tractor! Connect the chains in order to avoid rotating of the safety covers!

8. To assure a long reliability of the cardan shaft avoid angles bigger than 15°.
9. When using safety cardan shafts, the so called “ALLAN’S” bolt must be screwed in with a torque of 40 Nm. Check the torque after 2 minutes of operation.

9 DETAILED DESCRIPTION WITH INSTRUCTIONS FOR USE

Sprayer chassis is of steel welded construction; there is a main tank with flushing tank and clean water tank (washing hands) fastened on the chassis. There is a pump fastened on the front part, and a blower with a multiplier and adjustable fan fastened on the rear part. The multiplier and the pump are connected via transmission shaft.



WARNING:
Sometimes it is necessary to check oil level in the multiplier and to lubricate the crosses on the transmission shaft (approximately 500 operating hours).

In the front, the sprayer is fitted with a pressure regulator with diverter valves, a suction filter, a valve for flow control and a regulation valve, or a control box if the sprayer is equipped with an electronic or remote control system (transfer to the tractor cabin).

9.1 RESERVOIR

The main reservoir is made of polyethylene which is resistant to chemicals. It has rounded edges and smooth inner walls for easier cleaning. The reservoir has a sloping bottom which assures a complete emptying of it. There is a sieve with cover mounted on the top of the reservoir. Do not remove the sieve while filling the reservoir with insecticide or water!

The front side of the main reservoir has an engraved litre scale, alongside a transparent tube containing a free floating red ball to facilitate visual reading of the quantity of the chemical solution in the reservoir.



WARNING:
Do not remove the strainer when the reservoir is being filled with water or spraying products!
Use protective gloves when handling insecticides!

9.2 TANK COVER

MAIN TANK LID

The tank lid is made of two parts. The smaller part in the centre is designed for more convenient filling of the tank with water.

The recommended method is filling with clean water (without any polluting agents).

To open the lid, unscrew it to the left; to close it, screw it to the right.



While in operation, the tank lid has to be closed!

If the reservoir is fitted with a cover, as shown on the figure below, never insert the tube into the reservoir through the cover when filling the reservoir and prevent contact between the spraying product and the filling tube, otherwise the inlet section of the tube may become contaminated! In the event of a pressure drop in the tube, the spraying product may flow back into the filling tube.

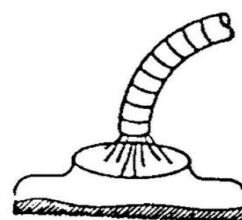
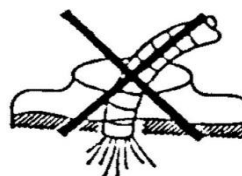

9.3 ABLUTION RESERVOIR

The abluion reservoir is meant for washing of the reservoir and other elements after you have finished working or after a break. Fill the reservoir with clean water. You can find more detailed instructions in the chapter "DESCRIPTION OF VALVE ADJUSTMENT FOR SPRINKLING OR CLEANING".

9.4 RESERVOIR FOR WASHING OF HANDS

This reservoir is meant for washing of hands after handling insecticides. Fill the reservoir with drinkable water. Its capacity is 15 litres (see technical data).



**WARNING:
Water in the tank for washing hands is not drinkable!**

9.5 MIXING NOZZLE



The sprayer is equipped with one or two mixing nozzles for better mixing of the mixture. The nozzles are mounted in the lower part of the reservoir. The mixing nozzle is controlled by means of the valve which is mounted on the pressure regulator. The mixing nozzle is operating when the lever of the valve is in upright position and vice-versa. It is recommended to turn on the mixing nozzle during insecticide preparation and driving to the field.

9.6 THREE-WAY VALVE – EJECTOR (only AGP 1000 PE)

On the bottom side of the tank, simpler versions of the machine (with a pump capacity of up to 100 l/min and without an additional tank) are equipped with a three-way valve that has a cleaning filter insert and a connector incorporated. The connector - through indirect help of the pump - enables the ejector to suck water from lakes, ponds or other watercourses into the main tank.



FUNCTIONS OF THE THREE-WAY VALVE (SEE PICTURE)

1. LEVER IN INTERNAL POSITION

In this lever position, the outflow of spray agent from the tank is stopped. It is possible to fill the tank

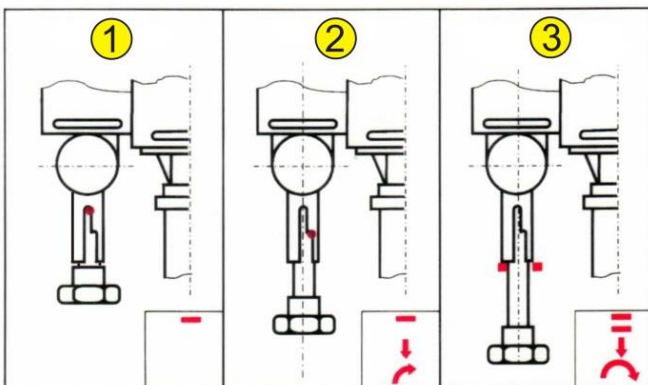

by placing the suction tube with basket (020.20.018) on the suction fitting (019.01.032) and the water will be drawn from low-lying positions (stream, well). The suction tube with suction basket is not part of the machine series equipment.

2. LEVER IN MIDDLE POSITION

The water outflow from the tank is enabled if the three-way valve is positioned under the tank.

3. LEVER COMPLETELY PULLED OUT

Normal functioning: the pump sucks water from

the tank through the cleaning insert in the three-way valve.

FILTER INSERT CLEANING

It is recommended to clean the cleaning insert of the three-way valve before each filling of the tank. To reach the insert, pull the bolt (019.36.314) and the output insert (019.01.030). Wash the cleaning filter insert under running water and place it back to its position in the ejector. The insert is point-shaped, therefore make sure you insert it correctly – the wider part has to fit into the inside of the valve body. If the cleaning insert has to be cleaned when the tank is full, push the lever in internal position before dismantling to ensure that the outflow from the tank is closed.

9.7 SUCTION FILTER

The suction filter is mounted between the reservoir and the pump. Its function is to filtrate the insecticide before it reaches the regulator. The size of the filter is 50 MASH.



FILTER INSERT CLEANING (SUCTION FILTER)

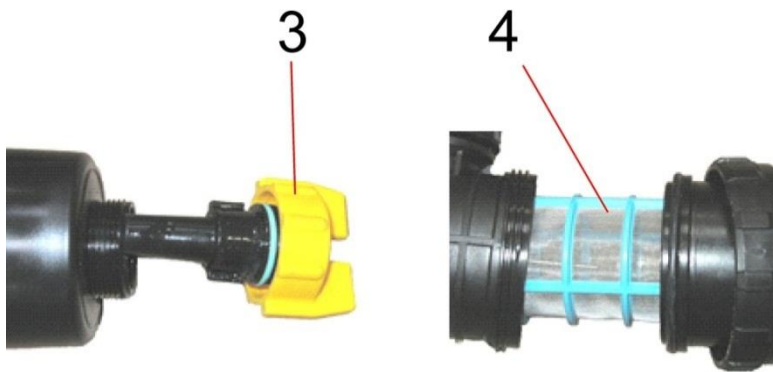

First, unscrew the yellow plug (3) on the filter lid (2) in counterclockwise direction and pull it out. The incorporated stop valve in the filter blocks the fluid inflow from the main tank. Unscrew the Holland nut (5) on the filter lid and the filter insert (4). Clean the filter insert and assemble the filter in reverse order.

When assembling the filter make sure that the stop valve metal needle, placed in the pull-out part (with the yellow plug), is correctly inserted, otherwise the filter will not operate correctly.



WARNING:
When cleaning the filter always wear protective gloves!
Clean the filter insert before each tank filling.

9.8 NOZZLE FOR CLEANING the main tank interior



The nozzle is located inside the main tank and is designed for washing the interior of the main tank after the spraying is finished. It is connected to one of the water supply ball valves mounted on the pump, which supplies the water necessary for cleaning the tank when the valve is opened.



The nozzle shown in the picture is symbolic and may differ from the actual configuration of the machine.

9.9. ADJUSTABLE AXLE



By all sprayers with wheels, the wheel axle is clamped in the chassis in a way that enables continuously variable adjusting of track width. Each axle is sideward fastened with four screws that must be slightly unscrewed for changing the width (the chassis must be lifted from the ground) and pulled out or pushed into the supporting tube of wheel axle for a chosen track width.¹ The axle must be re-tightened with screws which must be finally secured with a counter nut to prevent the screws from getting loose later.

9.10 BLOWER

Blower is a constituent part of the sprayer, in which a multiplier with a fan is clamped. There are nozzle brackets with nozzle inserts screwed on the outside frame (air outlet); however, there is a protective mesh screwed on the rear, air-inlet side. The blower is designed for producing air, to which spray agent drops are added. Spraying quality depends on the airflow quality (air amount and speed without turbulence). The airflow thus enables a quality drop transfer from the nozzle to the desired place on the plant. All blower versions, also those with a rectifier, are produced with a metal case.

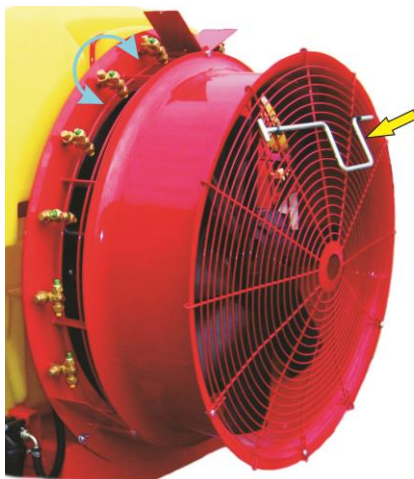

Key for adjusting the blower blades



Screw for adjusting the height of nozzle

Standard blower

Rectifier with adjustable nozzles

An advantage of the air rectifier is enabling a more even distribution of the air to the left and to the right sides of spraying, and to the whole height of the habitus. “Air quality” is a great deal better with a rectifier; therefore spraying with a low water consumption per hectare is possible with the help of a rectifier, which consequently lowers spraying costs.

9.11 FAN WITH ADJUSTABLE VANES

AIRSPPEED AND AIR AMOUNT

For a correct application of spray agent to plant parts, the airspeed and fan capacity must be adjusted to the plantation size and the vegetation season. Too high airspeed causes a loss of spray agent due to the increased drifting of drops; whereas too low airspeed causes insufficient protection on the inside of the habitus. When a small part of drops still penetrates the whole habitus, the airspeed is correct.

For each individual plantation and its development period it is most convenient to set the fan vanes after a practical test, in other words, to consider the recommendations for setting the fan vanes according to the following chart:

Fan Type	Purpose	Maximum Allowable Airspeed (m/s)	Degree of Vane Opening
Ø 825	Viticulture	30	1 – 2
	Fruit-Growing	40	1 – 3
	Hop-Growing	40	1 – 5

The chart was calculated for the rotating speed of 540 min⁻¹ on the tractor transmission shaft or 1940 min⁻¹ of the fan.

SETTING THE FAN

All Agromehanika pull-type sprayers are equipped with a fan rotating in the left, seen from the front side of the fan, or in the driving direction of the tractor.

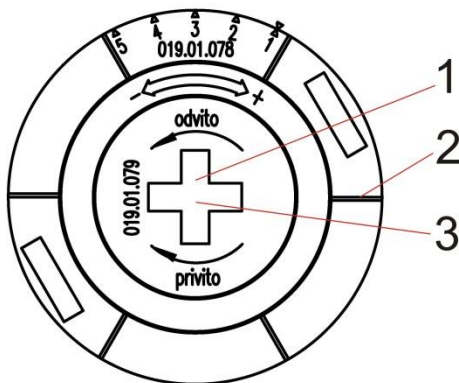

SETTING PROCEDURE:

1. Insert the fan setting key into a cross-shaped opening in the fixing nut, and with an impact to the left (in counterclockwise direction) loosen the fixing nut and unscrew it one half of the turn.
2. Lean the setting key on a rib in the regulation lid. With an impact on the key turn the lid to the left for decreasing the airspeed, or to the right for increasing it. The lowest outlet speed is at number 1, the highest at number 5.
3. Reinsert the key in the cross-shaped opening and screw the fixing nut with a turn to the right.

WARNING:

If the fixing nut is unscrewed too much when setting the fan, the regulation lid can get detached. In such case remove the protective mesh, turn the fan vanes in one direction manually (all the same way) and reinstall the regulation lid and regulation nut.



1. If the vanes are set on minimum air off-take, adjust the regulation lid in a way that the line with number 1 on the lid is aligned with the line on the fan hub.
2. If the vanes are set on maximum air off-take, adjust the regulation lid in a way that the line with number 5 on the lid is aligned with the line on the fan hub.

MULTIPLIER

The multiplier deals with the momentum transfer from the pump via transmission shaft (PTO) to the fan. Transfer is single-stage with a possibility of rotation shutdown (turning off the fan).

FAN SHUTDOWN:

The multiplier, with the fan rotating on its shaft, is on its side equipped with a shutdown handle that enables the fan switch-off. Choosing the turn-off position interrupts the connection between the fan and the pump, so the sprayer does not produce wind despite the switched-on PTO. Thus the sprayer may be used for other purposes (spraying with a stick, spraying with herbicide kit, pumping...).



WARNING:

Always perform the fan activation or shutdown with the help of a multiplier handle only when the PTO is switched off. When inspecting or repairing the sprayer, make sure the drive is off. If the sprayer is connected to the tractor, turn off the engine and take the key out of the lock.

9.12 NOZZLE BRACKETS

In accordance with the standards, the sprayers are equipped with double membrane brackets for nozzle inserts and with different nozzle inserts (a separate chapter is devoted to nozzles with their flows). The nozzle brackets are in fact valves and carry out the following functions:

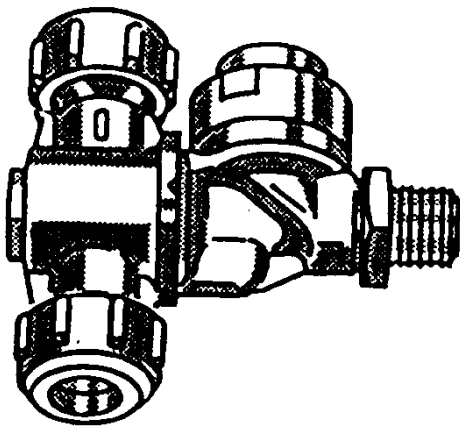

- In the case of rotation by 90⁰, the fluid flow towards the nozzle insert is open (closed). This enables the closing or opening of separate nozzles, depending on the needs and plant height.
- In the case of rotation by 180⁰, the fluid flow through some other nozzle is open (closed).
- Besides, the membrane valve, placed in the nozzle bracket, closes the flow at low pressures (closes at 0.8 bar and opens at 1.5 bar) and thus prevents the fluid leakage or outflowing, if the flow is closed at the supply or main valve.

10 VALVE ADJUSTMENTS

10.1 MIST BLOWER AGP 1000 PE

SPRAYING

By way of a three-way valve (5) the liquid flows from the main tank and through the suction filter inside the three-way valve and through the pump (4) into the pressure regulator (10). Open the ball valve (9) on the pump for mixing the spraying agent by means of a mixing nozzle (14). Then open the valves on the pressure regulator (10) to enable the supply to the nozzle section. The excess liquid flows back into the main tank via the pressure regulator.

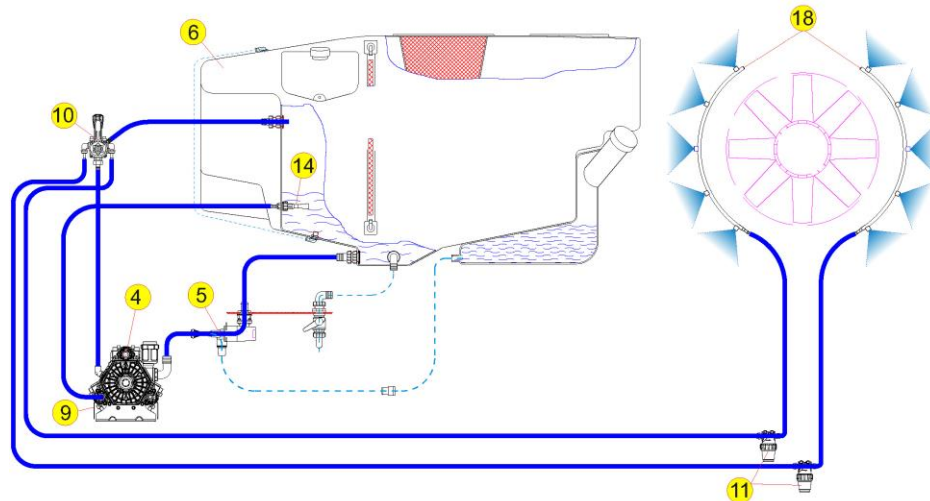

PARTIAL CLEANING

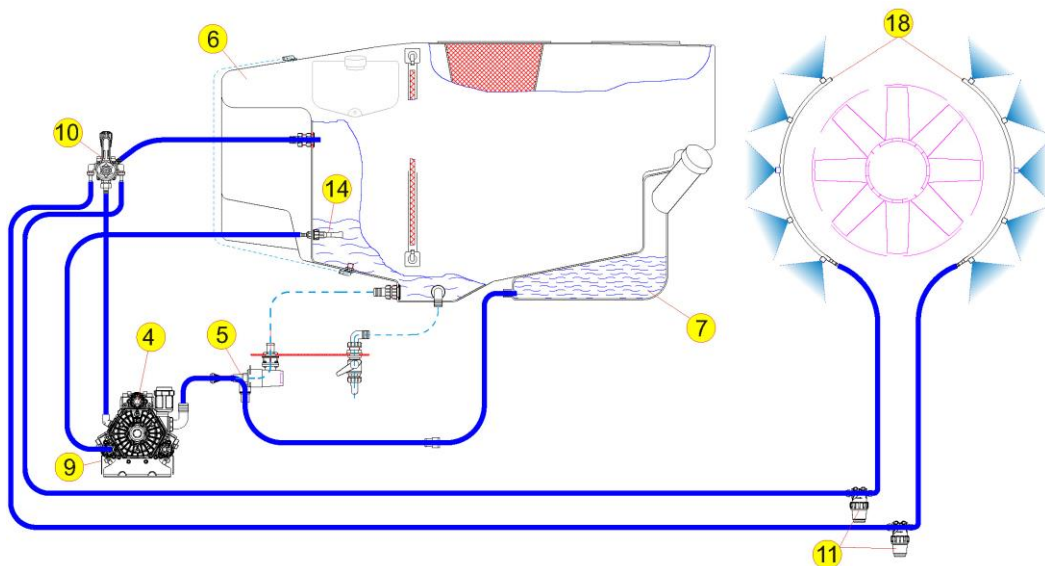

Partial sprayer cleaning comprises cleaning of the following elements:

- pump (4),
- pressure regulator (10),
- spraying arcs with nozzles (18).

Move the lever of the three-way valve (5) into the open position to enable the flow from the flushing tank (7). Make sure that the valve (9) on the pump for supplying the mixing nozzle (14) is also in the open position. The flow passing through the regulator must be routed into the main tank. After the water is pumped from the flushing tank, completely drain the main tank via the nozzles on the spraying arcs by opening the valve on the pressure regulator. The filter insert of the three-way valve and the inserts in the lateral filters must be cleaned manually.

10.2 MIST BLOWER AGP 1000 EN, AGP 1500 EN, AGP 2000 EN SPRAYING

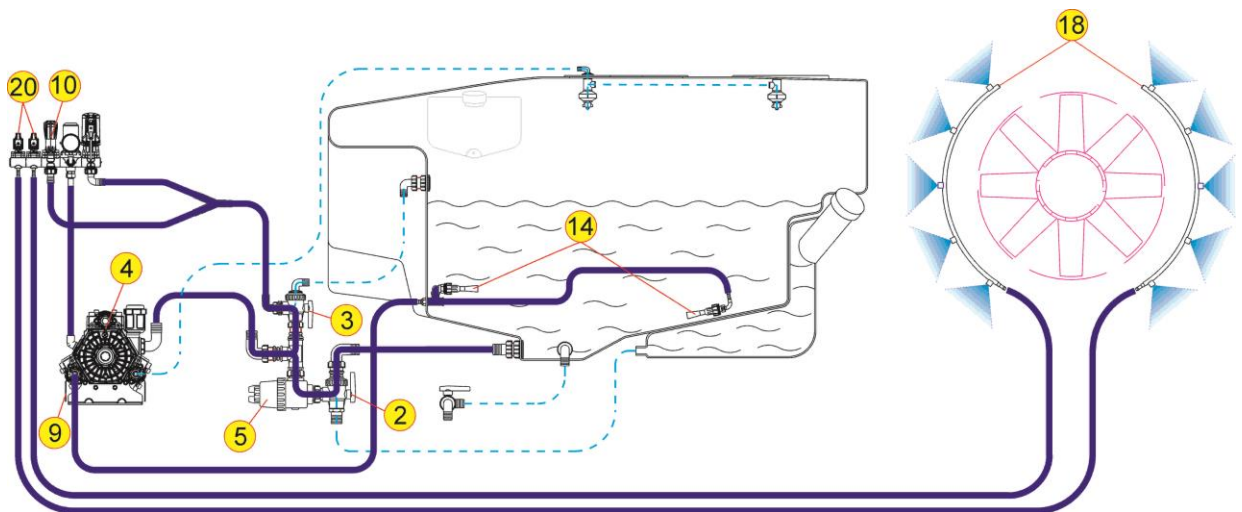

Spray agent is released from the main tank via three-way valve (2) through the filter (5) and the pump (4) into the pressure regulator (10). Open the ball valve on the pump (9) for spray agent mixing with the help of the mixing nozzle (14) and the valve for supplying nozzles sections (20). The flow direction through the three-way valve is marked on its handle with an »arrow«. The selector valve (3) must be opened so that it enables the fluid overflow from the regulator to return to the main tank.

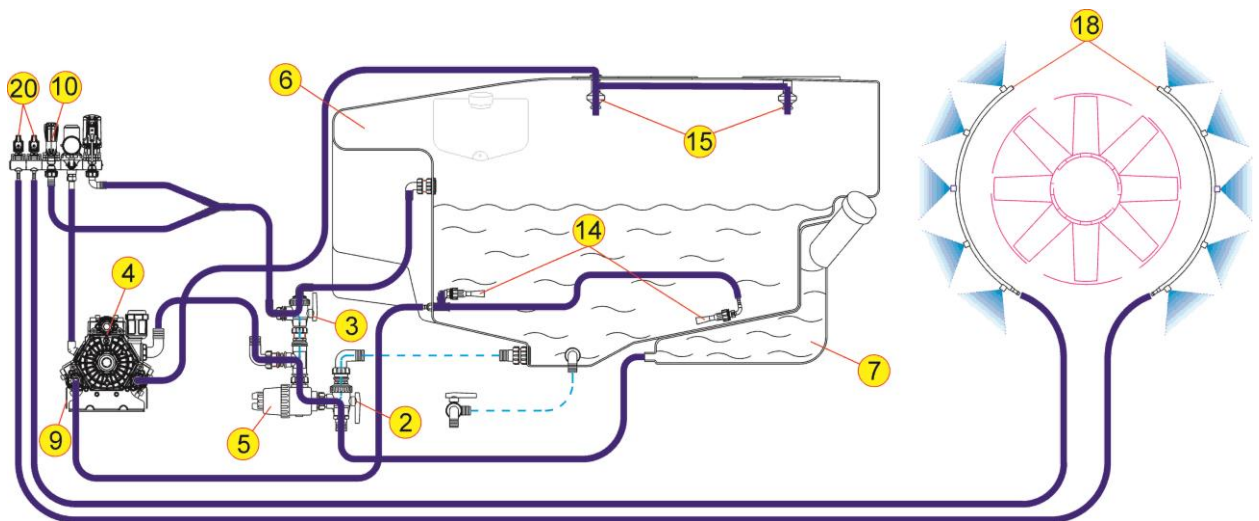

COMPLETE CLEANING

Complete sprayer cleaning comprises cleaning all of its interior parts:

- including the main tank (6),
- filter (5),
- pump (4),
- pressure regulator (10)
- and spraying tubes with nozzles (18).

Switch the three-way valve (2) to the supply from the flushing tank (7).

Pump all clean water from the tank through the pump (5) into the pressure regulator (6). Opening the valve for mixing nozzle supply (14). The flow from the pressure regulator through the selection valve (7.3) should be directed into the main tank. In the end, switch the three-way valve (7.2) to the initial position and empty the main tank entirely through the spraying tubes nozzles.

PARTIAL CLEANING

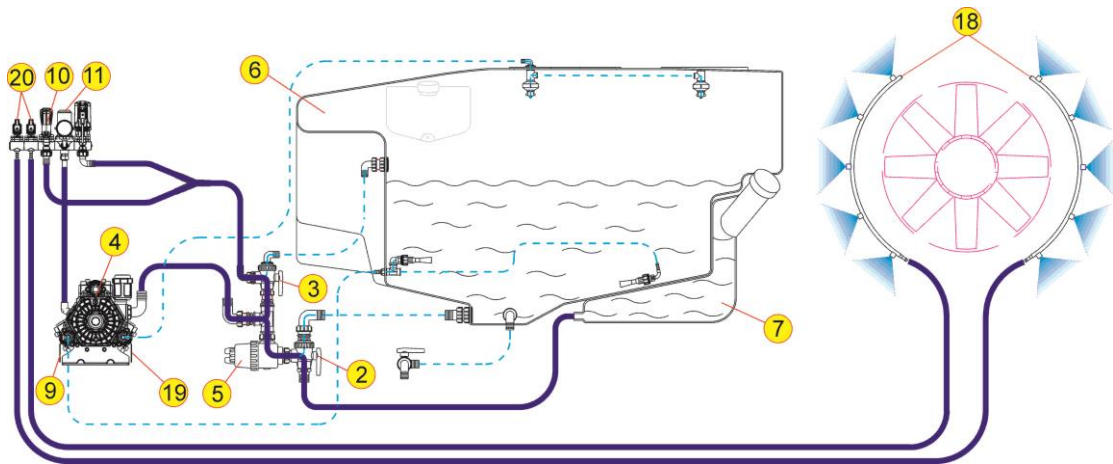

Partial machine cleaning comprises cleaning the filter (5), pump (4), pressure regulator (10) and spraying nozzles (18), without changing spray agent concentration in the main tank. Switch the three-way valve (2) to the flushing tank (7) and with the selection valve (3) redirect the flow directly to the pump (4). Close the mixing valve (9) on the pump. Clean water can thus flow unimpeded through the filter (5), pump (4), pressure regulator (10) and through spraying nozzles if the valve (20) is open. Spray agent concentration in the main tank remains unchanged.

11 OPTIONAL EQUIPMENT

This equipment comprises elements that are not included in the standard equipment of the mist blower. However, they can be additionally incorporated to facilitate the operation of the machine or improve the working efficiency of the machine. It includes:

- packaging cleaning valve (liquid products) and strainers;
- kit for rinsing the spraying product from the strainer;
- external washing set,
- manual remote-control regulation;
- electronic remote-control regulation;
- suction basket with a 5 m suction tube;
- external filling set;
- main tank flushing;
- terrace spraying equipment;
- signal lights.

11.1 SURFACE CLEANING SET

After finished working the sprinkling appliance needs to be cleaned. The most appropriate place for cleaning is at the edge of the surface where you have had just finished operating the machine. For this purpose, a set for outer cleaning of the sprinkling appliance is a big help.

The set includes:

- a sprinkling stick
- a flexible hose and
- an accessory part for connecting the sprinkling stick to the pressure regulator.

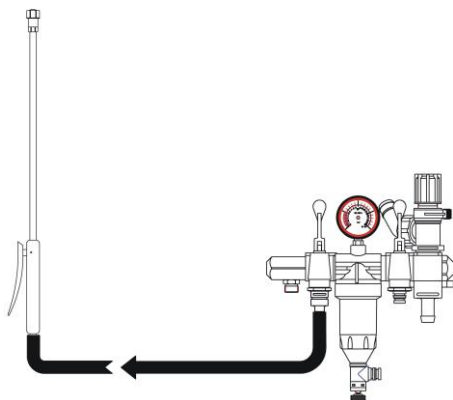

Connect the coupling extension of the set to a free diverter valve of the pressure regulator or to the disconnected section on the pressure regulator for mixing nozzles supply.

Set all other valves on the sprayer to the partial sprayer cleaning position (see previous chapter).

11.2 STRAINER FLUSHER

This addition enables a more convenient handling of spray agents. A special nozzle is incorporated in the strainer that directs the fluid flow from the nozzle to the bottom of the strainer, thus flushing the spray agent previously poured in the strainer. The flusher can be connected to the single diverter valve on the pressure regulator with the help of a tube connection between the valve and the mixing nozzle, or via the cleaning return line on the pressure filter of the pressure regulator.

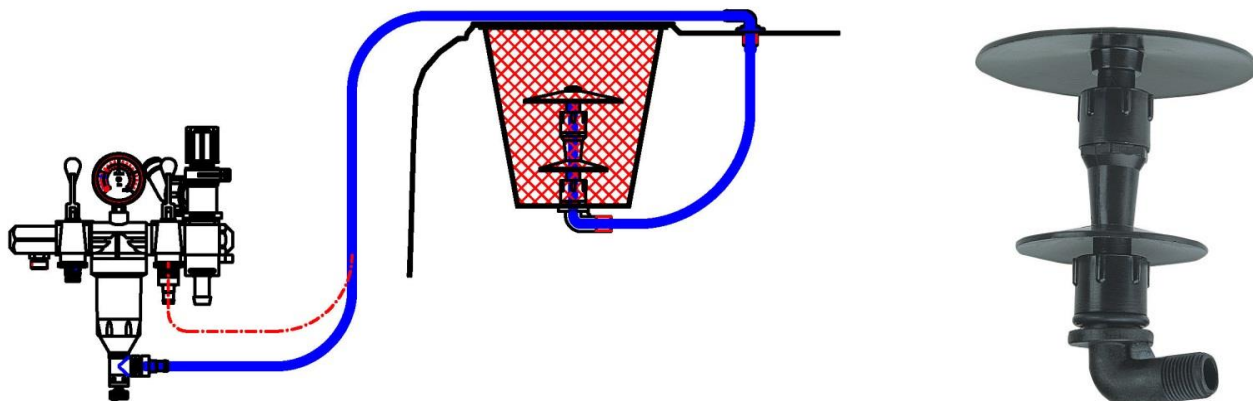

11.3 PACKAGING AND STRAINER FLUSHER

The packaging and strainer flusher is designed for washing the packaging of chemical plant protection products or flushing powder spray agents from the strainer into the tank. It is installed under the cover of the tank and connected to the diverter valve on the pressure regulator or via the cleaning return line on the pressure filter of the regulator. After using all the packaging (bottle) content, remove the (yellow) cover installed on the throat of the flusher, then push the neck of the bottle, including the throat, over the nozzle to the limiter (1). After that, push the bottle and the limiter (2) downwards, toward the bottom of the pouring sieve. This opens the valve and activates the nozzle that will thoroughly wash the inside of the packaging. When the bottle is removed, the valve closes the cleaning water flow.

When the supply of liquid to the packaging flusher is opened, the strainer flushing nozzle installed on the lower side of the flusher is also activated, which is why the tank cover must always be closed when you are flushing the packaging.

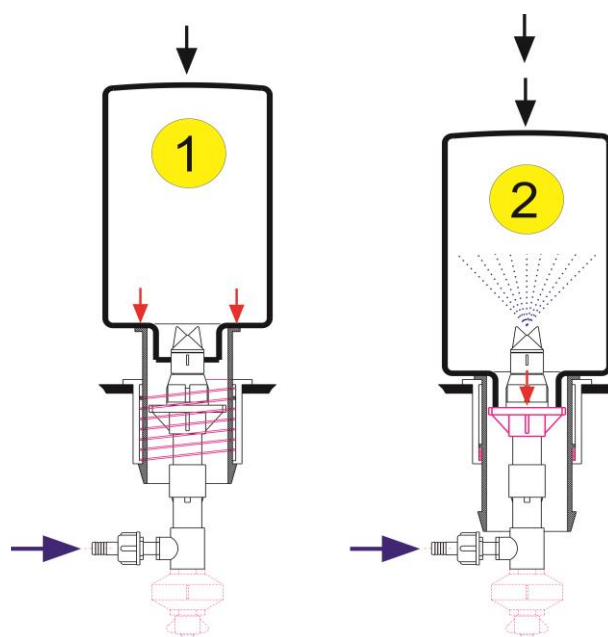

WARNING: Use protective gloves when handling insecticides!

11.4 SUCTION BASKET WITH SUCTION TUBE

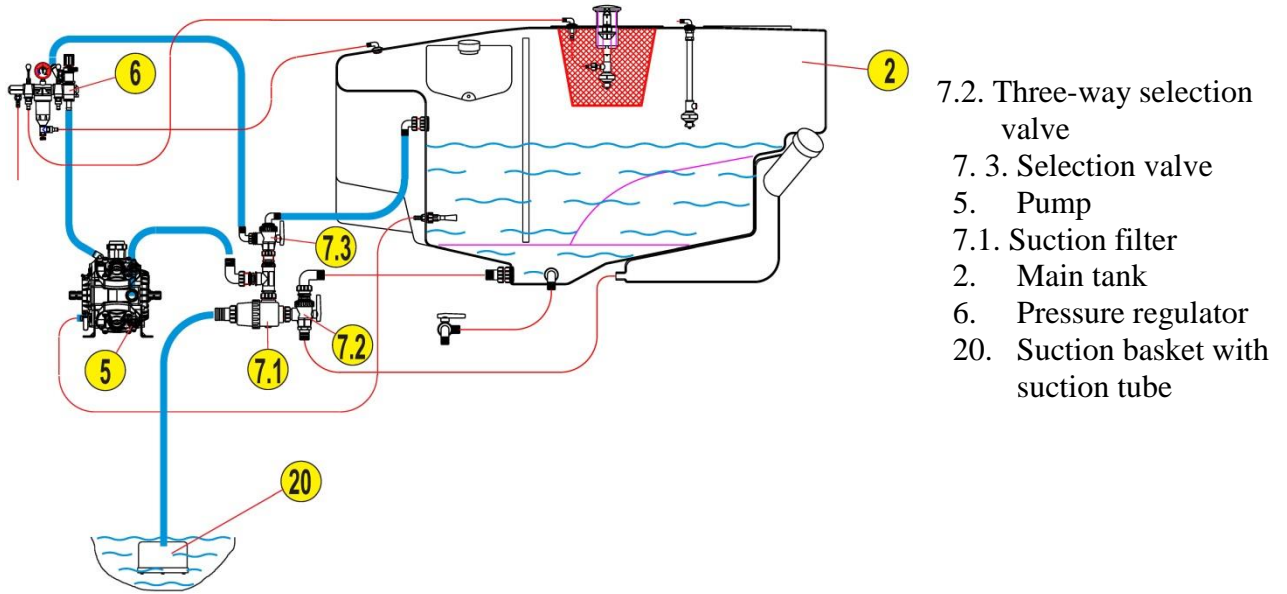

- 7.2. Three-way selection valve
- 7.3. Selection valve
- 5. Pump
- 7.1. Suction filter
- 2. Main tank
- 6. Pressure regulator
- 20. Suction basket with suction tube

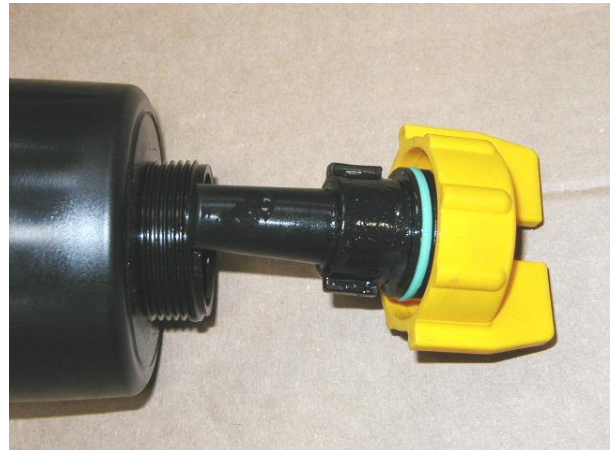
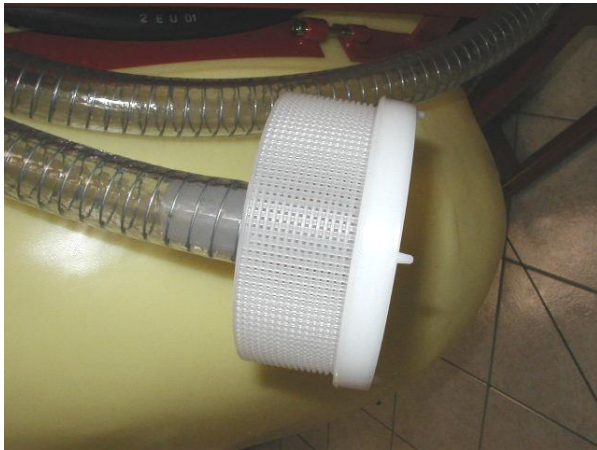

The suction basket is meant for sucking of water out of ponds, streams, fountains, etc. through the filter, the pump and the regulator into the main reservoir. It consists of the suction basket, 5 meters of suction hose and a connection piece for the filter. The connection piece is mounted to the suction filter in this way: remove the yellow lever and mount the connection piece that is attached to the suction basket instead of the yellow lever. Stretch the suction hose and plunge the suction basket into water. While doing this, be aware that deeper you sink the suction basket the more this affects the membranes in the pump. The height difference between the pump and the suction point should not be bigger than 3 metres. Before turning on the pump switch the lever of the central valve 2 (see chapter 10, “The flow valve”) to the position “Z” and close the three-way valve at the exit of the reservoir (outflow of the reservoir). The water flow is now directed from the suction basket to the suction filter, the suction pump and the flow regulator (return line) into the reservoir.



WARNING: Be very careful when sucking water out of a pond, since a small inattention can poison the water in it!

11.5 LONG RANGE SPRAYING NOZZLE BRACKET



When the spraying height becomes inadequate due to the height of the fruit trees, the sprayer can be fitted with nozzle brackets for long range spraying. Like the standard brackets, these are equipped with two outlets. The difference is that one side of nozzles can be regulated to adjust the nozzle range to reach higher areas up to the height of 5 m. Since these nozzles are designed for different (range related) spraying requirements, the spraying angle becomes narrower as the spraying distance increases, which leads to lower quality of spraying.

Another down side is that regulation also changes the nozzle flow, which means that it is theoretically impossible to control the consumption of the spraying product. The latter can only be determined by performing practical tests. These brackets are installed in the same way as the standard brackets and are therefore easily replaced.

11.6 ADJUSTABLE NOZZLE DEFLECTOR

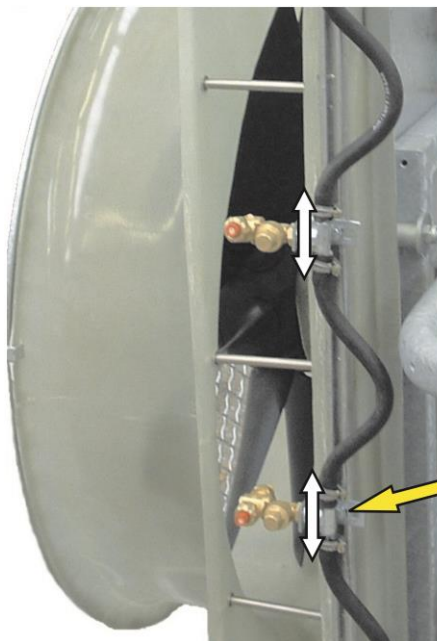

Screw for adjusting the nozzle height

The set consists of two vertical C profiles fitted with special slide guides with nozzle brackets.

When the brackets are released, they can be moved along the profile to adjust the distance between them. When the brackets are appropriately positioned, they only need to be secured with screws.

The system is useful because it enables the adjustment of the desirable spraying height

11.7 TERRACE SPRAYING KIT

The kit is designed for protecting orchards and vineyards planted in terraces; it can also be used for standard plantations. Nozzles on air rectifier are divided into 4 sections:

- top left
- top right
- bottom left
- bottom right.

When spraying terraced plantations, open different nozzles combination (on a higher positioned terrace top quarter, and on a lower positioned terrace bottom quarter). After changing the driving direction, change the combination of open and closed sections.

The kit comprises:

- additional two diverter valves on the pressure regulator
- additional nozzles (6 or 8, depending on the rectifier version)
- tube connection of the regulator with nozzles.

11.8 SIGNAL LIGHTS

The signal lights are installed at the rear of the mist blower. It consists of a tin bracket fitted with left and right rear combination lamps, including all the lighting elements required for transporting the sprayer on public roads. The cable is connected to the tractor cab.



Signal lighting elements

12 PRESSURE REGULATOR

12.1 PRESSURE REGULATOR M170

Operation with high-pressure regulator M170 is manual.

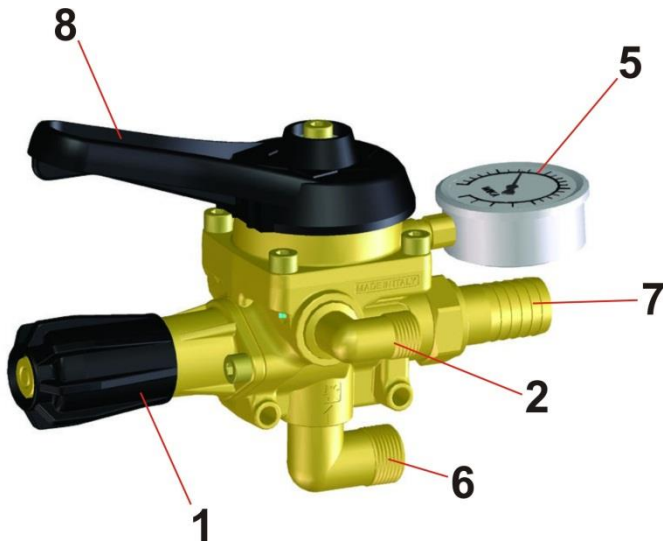

It can be used for remote manual regulation of machine working parameters from the tractor cabin, which is its advantage. It is used for operating pressures of up to 50 bar and for pumps with maximum flow capacity of 150 l/min.

It has no filter incorporated, therefore the machine, equipped with a filter, normally has the cleaning filter incorporated on the pressure side – between the regulator and spraying arcs (separately for each output)

1. Operating pressure adjustment nut
2. Pressure output
5. Pressure gauge

6. Pressure connector
7. Return connector
8. Adjustment lever

12.2 PRESSURE REGULATOR PR8

PR8 High-Pressure Pressure Regulator (Braglia) belongs to newer, electronic systems for remote control spraying with sprayers.

MANUAL PRESSURE REGULATION (PR8F/2EC)

It comprises the main regulation valve, enabling manual operating pressure regulation, high-pressure filter and electromagnetic diverter valves, whose opening and closing is enabled by the cabin control box.

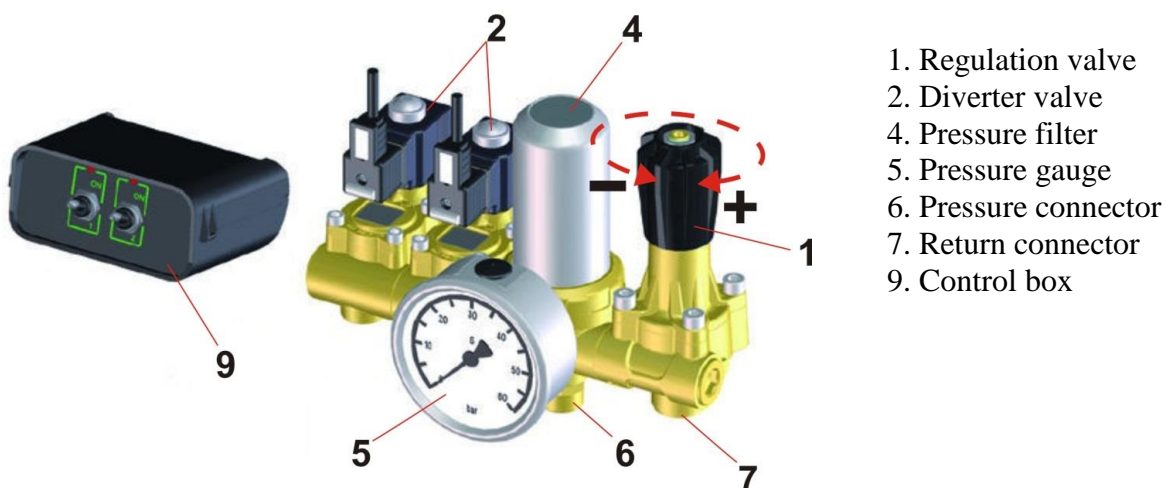

1. Regulation valve
2. Diverter valve
4. Pressure filter
5. Pressure gauge
6. Pressure connector
7. Return connector
9. Control box

It is distinguished by:

- a firm, robust construction, if the most quality materials are used, for unimpeded work at high operating pressures
- opening and closing of diverter valves with the use of electromagnetic valves
- an easy operation via portable keyboard from the tractor driver working position in the tractor
- safe and unhindered work.

REMOTE CONTROLLED PRESSURE REGULATION (PR8ECF/2EC)

A better version of the regulator (EC label) is apart from manual valve equipped also with an electromagnetic regulation valve, which enables the remote control operating pressure setting (from the cabin).

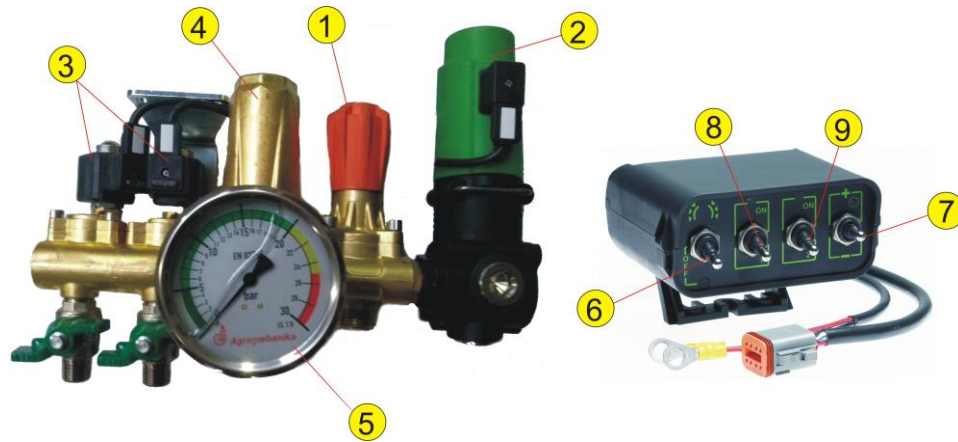

- 1- Main regulation valve
- 2- Solenoid regulation valve for remote pressure regulation
- 3- Diverter valves
- 4- Pressure filter
- 5- Pressure gauge
- 6- Main switch (ON-OFF)
- 7- Pressure adjustment (+ or -)
- 8- Spraying on one side(left or right)
- 9- Spraying on the other side (right or left)

12.3 PR9 PRESSURE REGULATOR

High-pressure regulator PR9 (Braglia) provides a state-of-the-art pressure control of all spraying functions. It is used in the system of fully electronic regulation or control of spraying functions of the mist blower and is one of the highest quality methods for computer control and operation of all the most important spraying functions. It is controlled with the M1 AG-TRONIK, specifically designed for mist blowers. Due to its volume, the User Manual of M1 AG-TRONIK is provided as separate booklet to all mist blowers equipped with this type of regulation.



- 1. Rough pressure regulation valve
- 2. M202 pressure regulator for automatic operating pressure adjustment
- 3. Pressure filter
- 4. Flow sensor
- 5. Diverter valves
- 6. Pressure gauge
- 7. AG-TRONIK M1

12.4 REGULATOR LABELLING

STANDARD MODELS

The pressure regulator label includes the regulator type, information on whether the regulator is equipped with a pressure filter, as well as the number and type of diverter valves.

Example:

The label PR8ECF/2EC identifies the type PR8 pressure regulator with remote controlled pressure regulation, high-pressure filter (F mark) and two solenoid diverter valves (numerical mark + EC).

REMOTE CONTROLLED MODELS

PR8:



The basic version of PR8 pressure regulator already enables remote opening and closing of diverter valves on the regulator by means of the keyboard installed in the tractor cab, which is connected to the tractor's electrical circuit.

M170:

Its label is standard because the regulator has a specific shape and there are no other versions.

12.5 MAIN COMPONENTS OF THE PRESSURE REGULATOR

CENTRAL REGULATION VALVE

M170:

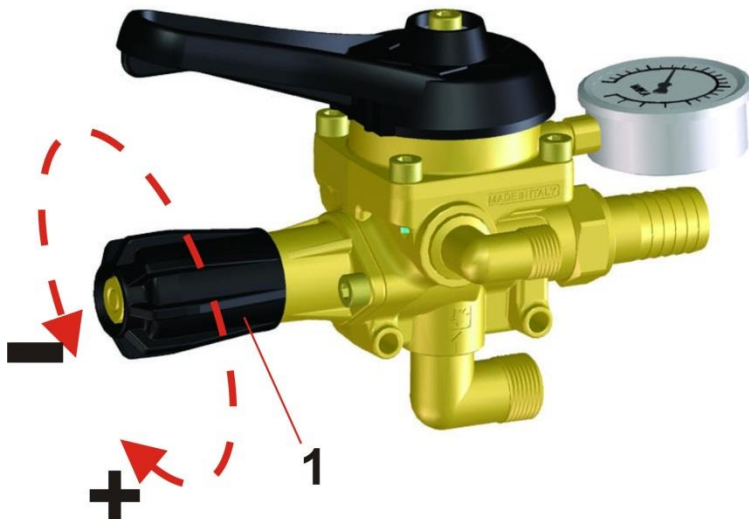

The regulation valve (pos. 1) enables manual adjustment of the operating pressure from 0 to 50 bar with a maximum flow capacity of 150 l/min at a continuous flow of liquid through the valve. The pressure can be reduced by turning the plastic nut at the top of the regulation valve to the left (-) or increased by turning the nut in clockwise (+).

PR8:

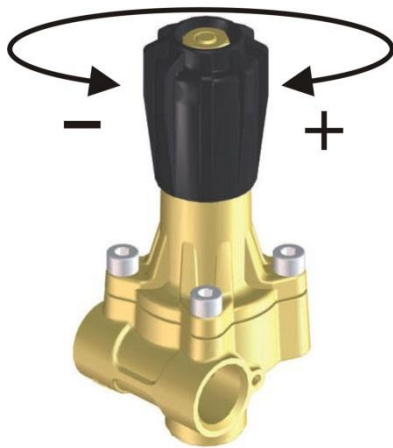

IMPORTANT:

When reducing the pressure, take care not to loosen the nut too much (when you wish to reduce the pressure to below 1 bar), otherwise the nut may fall off the regulator along with some other essential regulator components.

The PR8 regulation valve enables manual adjustment of operating pressure from 0 to 40 bar and its maximum flow capacity is 160 l/min at the operating pressure of 2 bar. The pressure is reduced by turning the plastic nut at the top of the regulation valve to the left (-) or increased by turning the nut in clockwise (+).

In addition to the manual regulation valve, the EC version is also equipped with a solenoid regulation valve that enables operation from the tractor cab.



IMPORTANT:

During normal use, make sure that the manual regulation valve is fully tightened, otherwise the regulation through the solenoid valve will not work.

PR9:



The electric motor solenoid valve for automatic pressure regulation from 0 to 40 bar is an integral part of the PR9 high-pressure regulator.

PRESSURE FILTER

PR8, PR9:



The PR8 and PR9 pressure regulators are equipped with a robust and compact high-pressure filter. Inside the filter there is a filter insert containing a stainless steel mesh of a M40 density. Because the filter does not come with a self-cleaning feature, it must be occasionally opened with a special wrench, which is provided, and cleaned.

If you are using powdered chemical agents, it is recommended that you clean the filter insert before each spraying to ensure trouble-free spraying.

M170:



The M170 pressure regulator assembly is not equipped with a cleaning filter, therefore the machines into which this regulator is incorporated are additionally fitted with autonomous pressure filters – separately for each pressure line.

To clean the filter, manually unscrew the cover at the base of the filter and wash the cleaning mesh with clean water.

If you are using powdered spraying products, follow the procedure for cleaning the pressure filter of the PR8 or PR9 pressure regulator.

DIVERTER VALVE

PR8, PR9:



The solenoid diverter valve performs the same function as the manual valve, except that it is operated with a keyboard installed inside the tractor cab (remote regulation).

The valve is robust and enables an operating pressure of up to 40 bar. Its construction enables the remote supply of one or two connectors:

1. The supply of spraying arc, mixing nozzle, flushing nozzle etc.
2. The connector enables a direct flow without the option of opening/closing regulation.

If the user wishes to use this output so that it can be closed when necessary, it must be fitted with an additional ball valve.

M170:

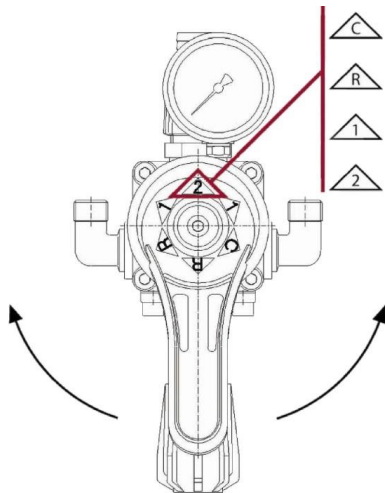

The M170 pressure regulator is equipped with two diverter valves (left/right side) that can be opened/closed with a large lever at the front side, which can be rotated by 360°. The lever enables opening and closing of an individual section or both sections together.

Operating positions:

C- all lines closed

R- tank return line open

1- one pressure section open (left/right)

2- both pressure sections open

12.6 REGULATOR OPERATION ADJUSTMENT

- Always use clean water to perform adjustments.
- Calculate the required driving speed according to consumption per hectare and sprayer flow.
- Adjust the tractor revolutions according to the calculated driving speed and take into account the required (about 450 rpm) or the maximum number of revolutions of the PTO shaft (540 rpm).

M170:

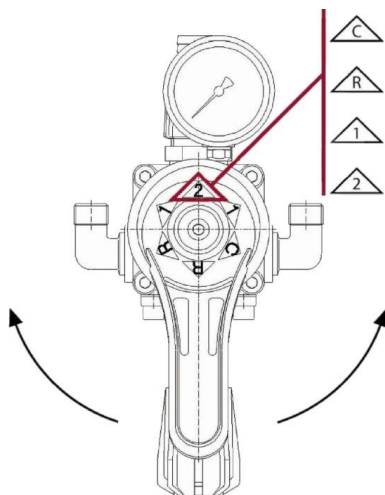

1. Open the diverter valves on the spraying sections (pos. 2);
2. adjust the operating pressure to the desired value.

PR8:

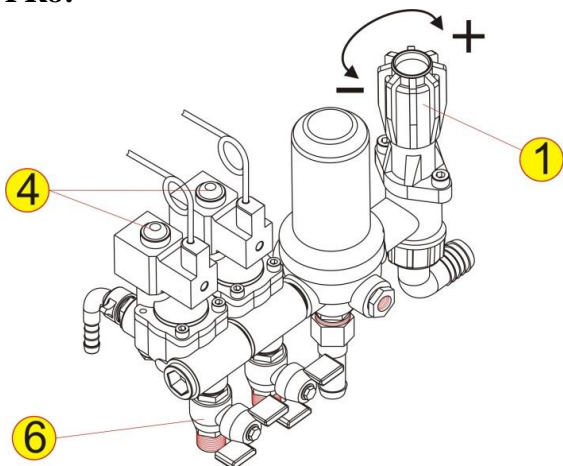

1. Open the diverter valves supplying the spraying nozzles (4) and the mixing valve (6) by means of the remote control keyboard.
2. Manually adjust the operating pressure of the regulation valve to the desired value.

WARNING:

When adjusting the operating pressure make sure that the engine revolutions match the revolutions used to select the working speed.



PR9:

Due to its volume, the User Manual for PR9 pressure regulator is provided as separate booklet to all mist blowers equipped with this regulator and contains all detailed instructions for correct adjustments and use of the pressure regulator.

12.7 PRESSURE REGULATOR MAINTENANCE

After every spraying the pressure regulator must be washed with clean water. Spray agent residues cause an additional corrosion of the regulator seals and reduce their lifespan. For this follow the instructions on partial or complete machine cleaning, dealt with in a separate chapter.

Some other maintenance instructions for particular machine components:

Lubrication is recommended for all seal joints with O-rings.

1. All regulator folding parts and threads must be lubricated with oil or WD-40 every 40 hours. Also before joining the connecting mouthpieces, first clean them thoroughly, lubricate the O-ring seals with grease and construct them. Whilst constructing slightly rotate the extension to prevent the seal damage.
2. In winter, release all the water from the regulator.



WARNING: Always use protective gloves when cleaning the regulator!

13 PUMP

Pump is a vital element of sprinkling appliance. The reliability and a long durability of the pump also depend on how you treat the pump and whether you use and maintain it correctly.

Pump, incorporated in sprayer, belong to the category of medium pressure membrane-plunger pump, made from materials verified by the manufacturer and intended to pumping the spray agents and liquid fertilizers, used in agriculture, arboriculture and viticulture.



IMPORTANT: In their standard versions, all pumps are equipped with membranes made from NBR rubber; therefore, the user is obliged to use such chemical spray agents that do not damage the material. If the user applies chemical agents that are more aggressive, the manufacturer declines all responsibility for any pump damage.

13.1 CHECK BEFORE USING THE APPLIANCE

When the pump is not operating check the oil quantity in the housing of the pump. Also check the oil level every single time before filling the reservoir. The level must be within the limits which are marked on the oil lid or in the oil pot (depends on the version of the pump). If the oil level is too low add some oil whereas be careful not to exceed the maximum allowed level.

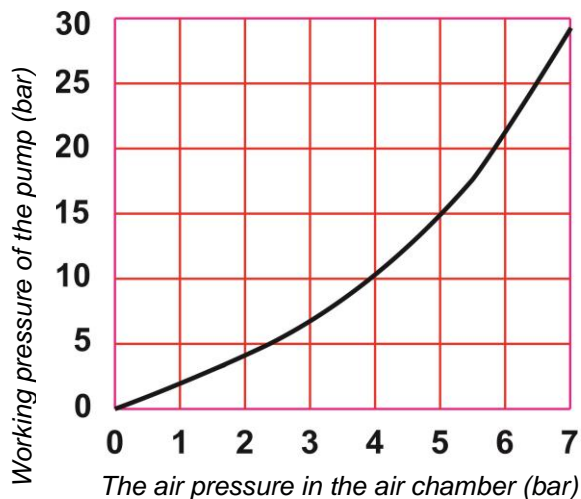

The air pressure in the air chamber depends on the working pressure which can be found in the diagram on the left. The air pressure in the air chamber must never be higher than the working pressure of the pump.

13.2 USE

Before starting the pump drive, make sure the main pressure regulator valve is in a free-flow position (open tank return line).



Never turn on the pump's drive when the setting on the regulator enables full stressing of the pump.

Turn on the pump and let it run for approximately one minute under minimum pressure in order to aerate the pump and the inlet and the outlet pipes. After one minute the pump is ready for operation. Be careful not to exceed the maximum allowed pressure and the maximum allowed rpm of 550. On the opposite, the manufacturer cannot be held responsible for any kind of damage that could occur.

13.3 AFTER USE

Some chemical agents can shorten the durability of some vital parts of the pump such as rubber membranes and/or other rubber sealings. Therefore a thorough washing of the pump after every single sprinkling is recommended. To do this, you will need to pump some clean water through the pump. Let the pump operate at working pressure for several minutes. Lower the pressure and let the pump operate for approximately one minute to blow out the rest of the liquid. During winter, leave all of the water out of the pump and/or protect the pump against freezing (see chapter "Maintenance and storage after use").

13.4 TECHNICAL DATA

PUMP IDENTIFICATION		PA 930	PBO 1250
FLOW QUANTITY	l/min	92,0	125,0
Max. OPERATING PRESSURE	bar	40	50
Max. ROTATIONS NUMBER	o/min	550	
NEEDED POWER	kW	7,0	11,8
PRESSURE-MEMBRANE NUMBER	piece	3	
MASS	kg	19,5	25,3
OIL	SAE	SAE 30	

13.5 PUMP MAINTENANCE

OIL CHANGE



Oil max. level

Oil min. level

Always use the recommended oil only (see the above chart, or the pump registration plate, or the oil lid on the pump itself).

First oil change is done after the initial 100 pump operating hours, then, after every 500 pump operating hours, or at the end of every working season. When changing the oil, also check the state of pressure membranes and replace them with new ones even if they are undamaged.

– **PUMP PA 930**

To control the membranes, unscrew the screws (pos. 46) on pump lids (pos. 5) and take the lids off. Check the outer and inner sides of all membranes and release the oil at the same time. Reconstruct the pump in reverse order. Before the pump is reassembled, it is recommended to check its interior and wash its vital components with gas oil. Make sure that the valves are correctly inserted (see the catalogue). Then add oil through the oil crucible (pos. 66). Whilst pouring the oil, manually turn the pump shaft several times to suck the air from the space between the plunger and the membrane. For some minutes, Start the pump at minimum pressure and let it run for a few minutes. Pay attention to its operation and, if necessary, add more oil. Make sure that the oil level is approximately between the max and min lines on the oil crucible.

– **PUMP PBO 1250**

The procedure for checking the membranes is the same as described for the PA/S 908 pump, with the difference that the screws (pos. 47) must be unscrewed from the pump cover (pos. 46). All the other steps are the same as indicated for the PA/S 908 pump.



WARNING:
Collect the waste oil in a special container and take it to an authorised client. Do not dispose of it in nature!

PUMP MAINTENANCE INTERVALS

Operation	Intervals			
	Every 8 hours	Every 50 hours	Every 300 hours	1x per season
Oil level check	X			
Pressure check in the air chamber		X		
Check of the pump attachment to the frame		X		
Membrane check and replacement if necessary			X	
Oil change			X	
Valve check			X	
Check of screw joints				X

14 CLEANING THE MACHINE

The sprayer must be thoroughly cleaned after every use. Spray agent residue is most conveniently used if it is diluted with clean water and applied on areas already treated. Its concentration should be at least 10 % (10 units of water per one unit of spray agent), the driving speed a bit higher, whereas the working pressure should be lower (5-7 bar, depending on the sprayer).

Such a procedure is possible with sprayers, equipped with an additional flushing tank. A special chapter - COMPLETE SPRAYER CLEANING - is devoted to the working methods.

In the end, wash the sprayer thoroughly from the inside and outside, and also clean all tools used whilst spraying, including the tractor.

For cleaning, use detergents, recommended by the producers of protective agents. If the instructions for use of the protective agent have additional cleaning instructions, follow them.

In harmony with local legislation about flushing of the pesticides in the ground, consult a Professional Advisory Service about sprayer cleaning methods.

Sprayer cleaning (pesticides flushing) must not be carried out on swampy grounds, near streams, water reservoirs, trenches, wells, etc.

Whilst cleaning, carry out calibration several times (measure the flow of one or more nozzle inserts at a particular working pressure. If the nozzle inserts flow deviates from the values set out in the chart by more than 10%, it is recommended to change them.

In the case of an unexpected operating interruption for a period of time while the spray agent is still in the tank, it is recommended to clean the pump, pressure regulator and spray tubes with clean water (see chapter "PARTIAL SPRAYER CLEANING").

If the spraying was unexpectedly interrupted and the sprayer was not cleaned, **the access to the machine must be blocked for other people and animals.**

NOTE:



- Clean machine is a safe machine.
- Clean machine is ready for operation.
- Clean machine will not be damaged by chemical agents and its solvents.

For cleaning choose and use suitable protective clothing. Choose suitable cleaning detergents and – if necessary – appropriate spray agents neutralizers (see the recommendation of the spray agent producer).

If you use detergents, a mixture of water and detergent, pour them into the main tank, close the main valve on the pressure regulator, turn on the pump, open the diverter mixing valve, open the self-cleaning filter valve, and only after several minutes, open the diverter valves for distribution to the nozzles. Pay attention to where you release the cleaning agent. Some detergents take effect only after some time, which prolongs the cleaning procedure (see the producer's instructions).



WARNING: Be careful with detergents; follow the instructions of the detergent producer.

After cleaning with the detergent, fill at least 1/5 of the tank with clean water and repeat the cleaning procedure. Be systematic and clean all elements that came in contact with the spray agent or detergent. Thoroughly clean all filters and be careful not to damage the fabric on the filter insert. If the filter insert is damaged, replace it with a new one. Descriptions of pressure filter, suction filter and three-way valve-ejector are found in separate chapters.

In the end, clean all nozzles. Clean nozzles with a soft brush, compressed air or water. Every cleaning of a nozzle with a solid object may damage it.



WARNING: If the sprayer is cleaned with a high-pressure cleaning aggregate, it is recommended to lubricate all movable parts of the sprayer with oil after cleaning.

15 MAINTENANCE AND STORAGE AFTER SPRAYING SEASON

After the end of spraying season, take some time to prepare the sprayer for storage. Before storing it, thoroughly clean the whole sprayer from the outside and inside (pressure regulator, pump, strainers, selection valves, nozzles...). After the cleaning is over, make sure that all water is discharged from valves, the pump, nozzles... After a thorough cleaning, carry out maintenance works.

15.1 TUBES

Check if tubes and tube joints are waterproof. Damaged tubes must be replaced with new ones. A defective tube can cause a great loss of time in the middle of spraying season.

15.2 COLOUR

Some spray agents contain solvents that have damaging effects on the colour. Where the colour is damaged, remove the rust and apply new colour with a brush.

15.3 TANK

Make sure there is no spray agent residue in the tank. Chemical residues must not remain in the spraying device for a longer period of time, for they quickly decrease the lifetime of the tank and other components. Make sure the tank outflow stays open.

15.4 PRESSURE REGULATOR

Protect the pressure regulator from moisture and dust. It is recommended to lubricate all movable parts with WD-40 or oil. More about maintenance can be read in the chapter "PRESSURE REGULATOR MAINTENANCE".

15.5 TUBE JOINTS

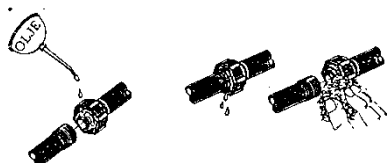

Reasons for improper sealing of tube joints:

- missing seals
- damaged or improperly inserted seal
- dry or defective seal
- unsuitable connectors.



In the case of poor sealing or leakage:

DO NOT SCREW the joint too hard for it can be damaged, rather dismantle the joint, check its state and position of the seal, lubricate and reconstruct it.

Use non-mineral lubricants (bio lubricants) for lubricating.



NOTE:

- by radial sealing it is enough to fasten the extension with your hand
- by axial sealing use a weaker force with hand tools.

15.6 SCREWS



IMPORTANT: Check the screws, bolts and especially protective bolts, their state and how firmly they are screwed. If necessary, fasten them or replace them with new.

15.7 OTHER PARTS

Also other vital parts, such as filter inserts, pouring strainer, additional equipment ... must be cleaned, checked for its state and if necessary replaced with new parts. Release water from elements like suction filters, and if necessary remove sediments. Lubricate joints and sliding members of the machine with an appropriate lubricant.

15.8 PROTECTION AGAINST FREEZING



WARNING: In winter conditions (when freezing) protect the sprayer to prevent the frost from damaging it!

It is necessary to:

- either release water from the pump, regulator, tubes, filters, and other elements....
- or store the sprayer in a warm place;
- or use an antifreeze agent (antifreeze) according to the following procedure:
 1. After you have finished cleaning the spraying appliance, completely empty the reservoir and pour at least 10 litres of antifreeze agent (a mixture of water and antifreeze) and turn on the pump.
 2. Open all valves on the regulator so that the antifreeze agent can reach all hoses and nozzles.
 3. At the end, drain the remaining agent from the reservoir into a container and let the pump operate for few more minutes in order to pump the remaining agent into the reservoir and the container.

Protect the pressure gauge against freezing by unscrewing it from the regulator and storing it in a warm room. The pressure gauge must be stored in an upright position, otherwise the glycerine filling may flow out of it.



WARNING: Make sure that the antifreeze agent is poured into appropriate containers and do not discard antifreeze agents in nature.

15.9 PUMP

After spraying season, clean the pump from the outside and inside more thoroughly and prepare it for storage. Check the amount of operating hours and, if necessary, carry out maintenance works (changing of oil, membranes, seals...), or at least oil, waterproof ... control. If you find out some defects, use the time after spraying season to mend them. If you are not sure about the quality of your work, rather leave it to an authorised repairer. The description of maintenance works is found in the "PUMPS" chapter.

15.10 DRIVE/TRANSMISSION SHAFT

It is vital to clean and lubricate the protective bolt on the transmission shaft head for ensuring the safety function.

Every 40 operating hours check the protective elements, function and the state of the transmission shaft. Damaged parts must be replaced with new ones.

Every 100 operating hours check the state of transmission shaft protection and if necessary change its friction plates. Also check the state of transmission shaft and especially of the safety bolt. Replace damaged parts with new ones.

16 POSSIBLE ERRORS

SIGNS FOR ERROR	POSSIBLE REASON	CHECK / REPAIR
There is no liquid coming out from the nozzles even though the main valve on the flow regulator is opened.	<ul style="list-style-type: none"> - damaged or incorrectly inserted valves in the pump; - closed manual valve on the suction side; - the suction or pressure filter is clogged; - there is some air inside the suction line. 	<ul style="list-style-type: none"> - check and if necessary replace valves in the pump; - check the valves on the suction line to the pump; - clean or replace the filter insert; - check the tightness of the hose junctions on the suction side.
The insecticide jet is unsymmetrical.	<ul style="list-style-type: none"> - inappropriate pressure in the air chamber. 	<ul style="list-style-type: none"> - check the air pressure in the air chamber and fill it according to the data
The pressure is falling according to the manometer; the working pressure cannot be reached.	<ul style="list-style-type: none"> - the suction or pressure filter is clogged; - the pressure hose is broken; - the valve of the self-cleaning filter is opened; - incorrectly chosen or too worn nozzle inserts; 	<ul style="list-style-type: none"> - clean or replace the filter insert; - replace the hose; - close the valve of the self-cleaning filter; - check the flow rate through the nozzles – if it is bigger than 10%, replace the nozzles;
The pressure on the manometer is strongly swinging.	<ul style="list-style-type: none"> - there is some air inside the suction line; - the membranes are damaged. 	<ul style="list-style-type: none"> - check the tightness of the hose junctions on the suction side; - stop the pump immediately; - replace the membranes and the oil inside the pump;
The pump is noisy.	<ul style="list-style-type: none"> - too low oil level; - exceeded maximum rpm 	<ul style="list-style-type: none"> - control the oil level and add some if necessary; - control the rpm of the pump.
There is some insecticide in the oil of the pump.	<ul style="list-style-type: none"> - damaged membranes. 	<ul style="list-style-type: none"> - stop the pump immediately; - replace the membranes and the oil inside the pump; - before mounting new membranes, thoroughly clean the inside of the pump with diesel oil.

17 TECHNICAL DATA

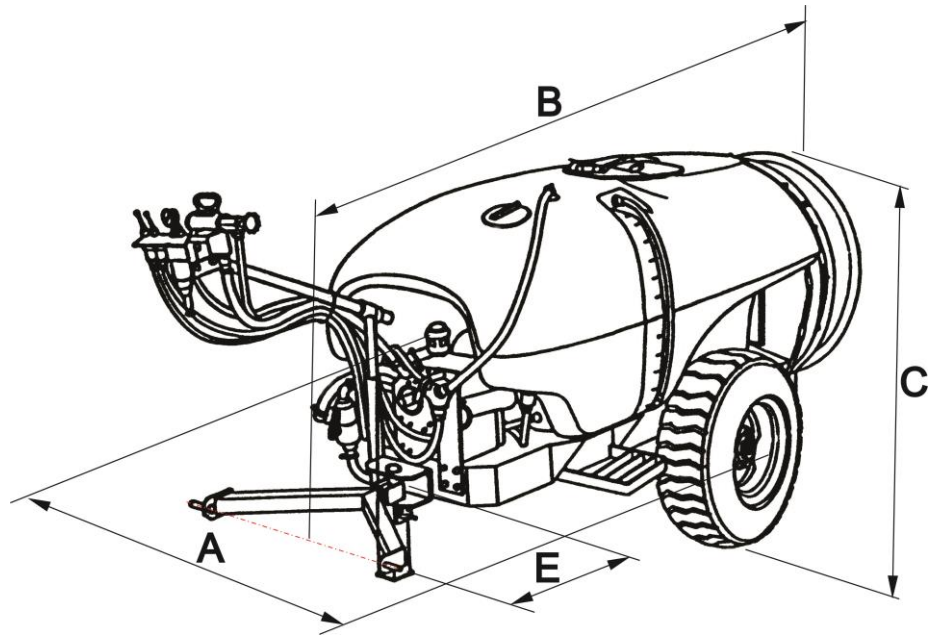

17.1 MIST BLOWERS WITH STANDARD FAN HOUSING

MACHINE TECHNICAL DATA		MACHINE LABEL			
		AGP 1000 EN	AGP 1500 EN	AGP 2000 EN	AGP 1000 PE
Tank nominal capacity	l	1000	1500	2000	1000
Tank Nominal Capacity	l	1099	1622	2127	1099
Flushing Tank Capacity	l	101	126		101
Capacity of Tank for Washing Hands	l	15,7			
Fan	dimensions	mm	Ø 825 Left Rotating Direction; Continually Adjustable tilt angle of fan vanes		
	capacity	m ³ /h	16000-48000		
Air Amount	m/s	<40 (continually adjustable by fan vanes tilt angle regulation)			
Output Airspeed	n/min.	2000			
Fan Rotations Max. No.		6 left, 6 right			
Number of Nozzle Brackets		Double, with anti-drip membrane valve			
Nozzle Bracket Type		LECHLER TR			
Nozzle Inserts Standard Type	cm	126x317x147	133x346x150	141x364x162	126x317x147
Dimensions (A _{Min} x B x C)	cm	47	47	0	47
Distance from Jack Pivot Centre to Tractor Connection (E)	cm	100-135	106,5-148	114-160	
Tyre Track (Adjustable)		10.0/75-15.3			
Tyres Dimensions	mm	330			
Clearance	kg	523	605	670	520
Machine Mass		Categories I and II			
Tractor Connector	kW	32-72 W			

17.2 MIST BLOWERS WITH AIR DEFLECTOR

MACHINE TECHNICAL DATA		MACHINE LABEL				
		AGP 1000 ENU	AGP 1500 ENU	AGP 2000 ENU	AGP 2000 ENU-SA OPRUGAMA	
Tank nominal capacity	l	1000	1500	2000	2000	
Tank Nominal Capacity	l	1099	1622	2127	2127	
Flushing Tank Capacity	l	101	126			
Capacity of Tank for Washing Hands	l	15,7				
Fan	dimensions	mm	Ø 825 Left Rotating Direction; Continually Adjustable tilt angle of fan vanes			
	capacity	m ³ /h	16000-48000			
Output Airspeed	m/s	<40 (continually adjustable by fan vanes tilt angle regulation)				
Fan Rotations Max. No.	o/min	2000				
Number of Nozzle Brackets:	Ø 825/1300		5 left, 5 right		/	
	Ø825/1300-reg.		5 left, 5 right		/	
	Ø 825/1700		7 left, 7 right			
	Ø825/1700-reg.		7 left, 7 right			
Nozzle Bracket Type		Double, with anti-drip membrane valve				
Nozzle Inserts Standard Type		LECHLER TR				
Dimensions (A _{min} X B X C)	Ø 825/1300	cm	126x317x179	133x346x179	141x364x179	/
	Ø 825/1700		126x317x217	133x346x217	141x364x217	141x364x237
Distance from Jack Pivot Centre to Tractor Connection (E)	cm	47	47	0		
Track (adjustable)	cm	100-135	106,5-148	114-160		
Tyres Dimensions		10.0/75-15.3			10.0/75-15.3 12.5/80R15.3 31.5x15.5x15	
Clearance	mm	330				
Chassis type		Toga			Suspension with leaf springs	
Machine Mass:	Ø 825/1300	kg	537	619	684	/
	Ø 825/1700		559	641	706	706
Tractor Connector		Category I or II				
Recommended Tractor Power	kW	32-72 kW				

17.3 MULTIPLER:

Type		ROTIS D21F
Gear ratio	i	1,3,9
Oil		HIPOIDOL SAE 90
Oil amount	l	1,75

17.4 TECHNICAL RESIDUE

TECHNICAL RESIDUE			EM	1000 EN/ENU	1500 EN/ENU	2000 EN/ENU
On even ground	diluted		1	10,50	37,20	45,00
	undiluted			0,60	0,80	2,00
On a 12 % gradient	transversal	driving to the left		17,60	20,20	22,00
		driving to the right		17,60	20,20	22,00
	longitudinal	driving upwards		24,20	34,00	40,00
		driving downwards		17,10	41,30	44,00

17.5 LABELLING:

Sprayers are labelled in the following way:

Example:

AGP 1000 ENU; PA 930; PR8 F/2 EMV

AGP..... abbreviation for sprayer

1000 tank nominal capacity

EN..... version, type

U.....air rectifier

PA 930... pump type

PR8F/2EMV.....pressure regulator type PR8 with a high pressure cleaning filter (F) and two diverter EM valves.

All other technical data for a particular component (pumps, flow regulators ...) are found in separate chapters of this manual. Find technical data for nozzles with charts, and examples of consumption calculations in chapter 15.

17.6 MATERIALS AND RECYCLING

TANK.....PEHD (high-density polyethylene)

MOVABLE TUBESRUBBER, PVC

FRAME.....STEEL

VALVES, PRESSURE REGULATOR, NOZZLE BRACKETS mainly PA (polyamide) with glass fibre

NOZZLE BRACKETS TUBES.....COPPER

17.7 MACHINE DISPOSAL

After the machine has served its purpose, it must be completely cleaned, disassembled, sorted according to the materials of each component, and disposed of to an organisation, dealing with waste. Tank and other plastic components can be recycled or burnt in waste incinerators; whereas metal parts must be separated as scrap iron. When dealing with waste, local legislation must be considered.

18 COMBINATION MATRIX

OSNOVNA IZVEDBA	MIST BLOWER								PRESSURE REGULATOR					PUMP		FAN HOUSING						ADDITIONAL EQUIPMENT							
	AGP 1000 PE	AGP 1000 EN (1000 I)	AGP 1500 EN (1500 I)	AGP 2000 EN (2000 I)	AGP 1000 ENU (600 I)	AGP 1500 ENU (1500 I)	AGP 2000 ENU (2000 I)	AGP 2000 ENU (2000 I) – Z VZMETNMI	M170	PR8 F/2 EMV	PR8 ECF/2 EMV	PR8 ECF/A EMV	PR9 ECFM/2 EMV	PA 930	PBO 1250 VD	STD	DEFLECTOR					SESALNA KOŠARA	ŠOBA ZA VISOKO ŠKROPLENIE	DODATNI TLAČNI FILTRI	IZPIRALEC CEDILA	IZPIRALEC REZERVOARIA	IZPIRANIE EMBALÁŽE V CEDILOU	RUDA GIBLIVA	TRANSPORTNA SIGNALIZÁCIA
																825/12	825/10 (1300)	825/10-REG. (1300)	825/14 (1700)	825/14-REG. (1700)	825/14-REG. (1700)-BOČNO ZAPIRANIE								
1	X							X					X		X					X	X		X	X	X	X	X		
2		X						X						X	X					X	X		X	X	X	X	X		
3		X							X						X	X					X	X		X	X	X	X		
4		X								X					X	X					X	X		X	X	X	X		
5		X										X			X	X					X	X		X	X	X	X		
6			X					X							X	X					X	X		X	X	X	X		
7		X							X						X	X					X	X		X	X	X	X		
8		X								X					X	X					X	X		X	X	X	X		
9		X										X			X	X					X	X		X	X	X	X		
10				X				X							X	X					X	X		X	X	X	X		
11				X				X							X	X					X	X		X	X	X	X		
12				X						X					X	X					X	X		X	X	X	X		
13				X								X			X	X					X	X		X	X	X	X		
14					X			X							X	X	X	X	X	X	X	X	X	X	X	X	X		
15					X				X						X	X	X	X	X	X	X	X	X	X	X	X	X		
16					X				X						X	X	X	X	X	X	X	X	X	X	X	X	X		
17					X					X			X		X	X	X	X	X	X	X	X	X	X	X	X	X		
18						X		X							X	X	X	X	X	X	X	X	X	X	X	X	X		
19						X			X						X	X	X	X	X	X	X	X	X	X	X	X	X		
20						X				X					X	X	X	X	X	X	X	X	X	X	X	X	X		
21						X						X			X	X	X	X	X	X	X	X	X	X	X	X	X		
22							X	X							X	X	X	X	X	X	X	X	X	X	X	X	X		
23							X		X						X	X	X	X	X	X	X	X	X	X	X	X	X		
24							X			X					X	X	X	X	X	X	X	X	X	X	X	X	X		
25							X					X			X	X	X	X	X	X	X	X	X	X	X	X	X		
26							X			X					X	X	X	X	X	X	X	X	X	X	X	X	X		
27							X				X				X	X	X	X	X	X	X	X	X	X	X	X	X		
28							X				X				X	X	X	X	X	X	X	X	X	X	X	X	X		

19 GENERAL INSTRUCTIONS FOR SPRINKLING

19.1 PREPARATION BEFORE STARTING OPERATION

For a successful sprinkling, the appropriate water quantity, right nozzle selection and a precise consumption calculation are of major importance. It is recommended to stick to the following order when it comes to preparing of the sprinkling mixture and sprinkling:

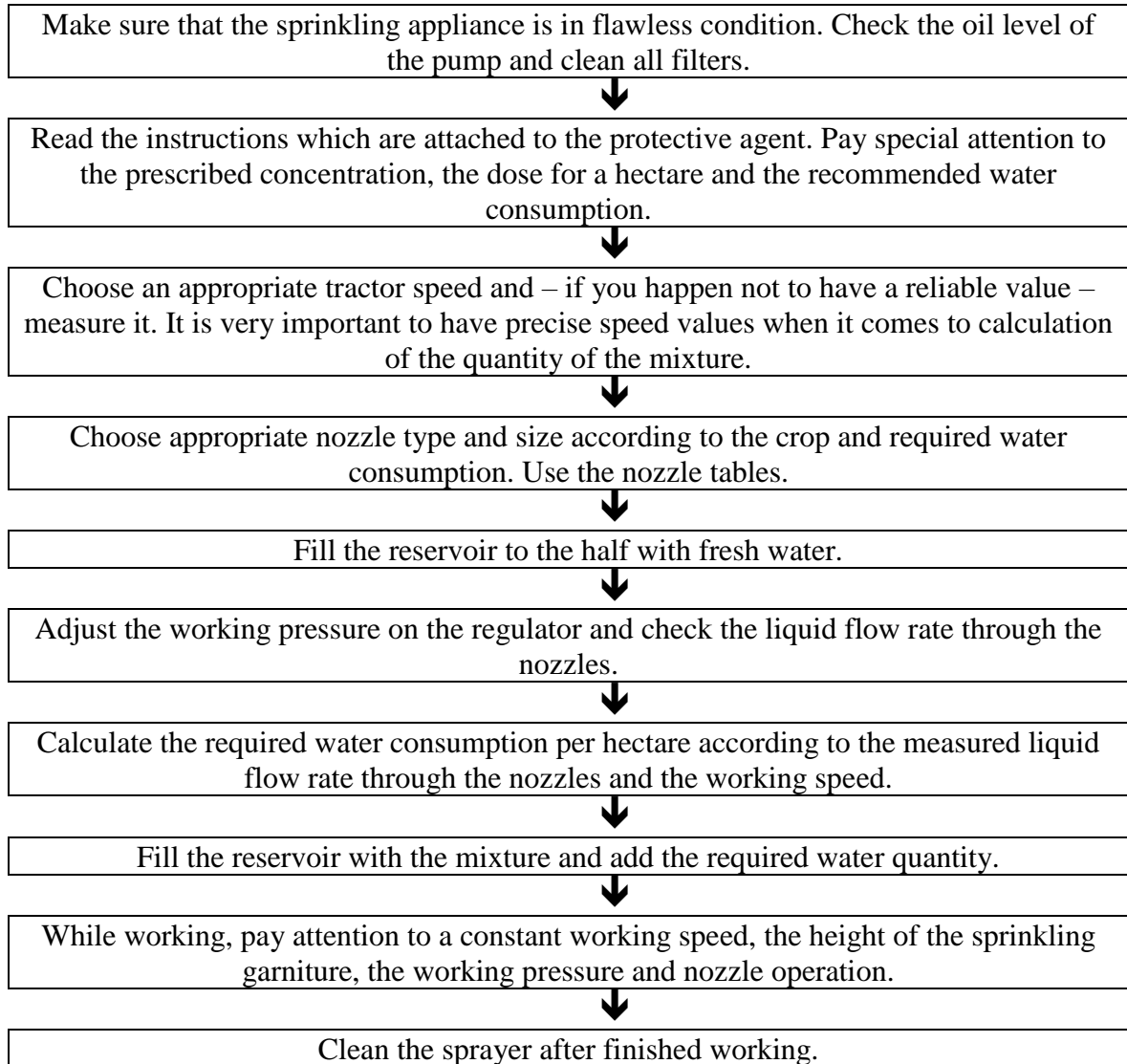

19.2 CONNECTOR FOR PUMP FLOW CONTROL MEASUREMENT

The pump flow indicator can be connected to the pressure regulator return line. The tube extension must be removed and another extension that is connected to the tank through the flow indicator must be installed in its place. While doing this, all other pressure regulator supply lines must be closed to ensure that the entire amount of the pumped fluid flows through the return line to the tank.

19.3 NOZZLE FLOW RATE CONTROL MEASUREMENT

To measure the flow rate through the nozzle, you will need a piece of soft flexible plastic or rubber hose with an inner diameter of 25 mm or 1" and an appropriate container (it is recommended to use a measuring cylinder). Simply put the hose on the nozzle and measure the liquid flow rate by catching the liquid of individual nozzles into the measuring cylinder. You will also need a stopwatch or a wristwatch. The measurement time is one minute. If you have performed the measurement in less than one minute, calculate the liquid flow rate to one minute.

If the liquid flow rate of a nozzle at a specific pressure exceeds the table values for more than 10% then the nozzle insert is worn and needs to be replaced.

20 TYPES OF NOZZLE INSERTS

In accordance with the standards, all sprayers of Agromehanika trademark are equipped with ceramic TR type nozzle inserts, made by a renowned German manufacturer LECHLER.

Nozzle inserts are designed for all kinds of detailed treating of habitus with protective agents, among which is also spraying with low water consumption.

These nozzle inserts are famous for the optimal size of drops, flow precision and minimal wear. They are ideal for working pressures between 2 to 20 bar.

20.1 CHARTS

CHART 1: Active driving time (min/ha)

DRIVING SPEED km/h	INTERLINEAR DISTANCE (m)												
	2	2,2	2,4	2,6	2,8	3	3,2	3,4	3,6	3,8	4	4,5	5
3	100	91	83	77	71	67	62	59	56	53	50	44	40
3,5	86	78	72	66	61	57	54	50	48	45	43	38	34
4	75	68	63	58	54	50	47	44	42	39	37	33	30
4,2	71	65	60	55	51	48	45	42	40	37	35	32	29
4,4	68	62	56	52	48	45	42	40	38	36	34	30	27
4,6	56	59	54	50	47	43	41	38	36	34	32	29	26
4,8	62	57	52	48	45	42	39	37	35	33	31	28	25
5	60	55	50	46	43	40	37	35	33	31	30	27	24
5,2	58	52	48	44	41	38	36	34	32	30	29	25	23
5,4	55	50	46	43	40	37	35	33	31	29	28	25	22
5,6	54	49	45	41	38	36	33	31	30	28	27	24	21
5,8	52	47	43	40	37	34	32	30	29	27	25	23	21
6	50	45	42	38	35	33	31	29	28	26	25	22	20
6,5	46	42	38	35	33	31	29	27	25	24	23	20	18
7	43	39	36	33	30	28	27	25	23	22	21	19	17

CHART 2: Required aggregate flow (l/min)

DRIVING TIME (min)	CONSUMPTION PER HECTARE (l/ha)												
	150	200	250	300	350	400	450	500	600	700	800	900	1000
15	10	13	17	20	23	27	30	33	40	47	53	60	67
20	7,5	10	12	15	17	20	22	25	30	35	40	45	50
25	6	8	10	12	14	16	18	20	24	28	32	36	40
30	5	6,7	8,3	10	12	13	15	17	20	23	27	30	33
35	4,3	5,7	7,1	8,5	10	11	13	14	17	20	23	26	29
40	3,7	5	6,2	7,5	8,7	10	11	12	15	17	20	23	25
45	3,3	4,4	5,5	6,6	7,7	8,9	10	11	13	15	18	20	22
50	3	4	5	6	7	8	9	10	12	14	16	18	20
55	2,7	3,6	4,5	5,4	6,3	7,2	8,2	9,1	11	13	14	16	18
60	2,5	3,3	4,2	5	5,8	6,6	7,5	8,3	10	12	13	15	17
65	2,3	3,1	3,8	4,6	5,4	6,2	6,9	7,7	9,2	11	12	14	15
70	2,1	2,8	3,6	4,2	5	5,7	6,4	7,1	8,6	10	11	13	14
75	2	2,6	3,3	4	4,6	5,3	6	6,7	8	9,3	11	12	13
80	1,9	2,5	3,1	3,7	4,4	5	5,6	6,2	7,5	8,7	10	11	12
85	1,8	2,3	2,9	3,5	4,1	4,7	5,3	5,9	7,1	8,2	9,4	10	12
90	1,7	2,2	2,7	3,3	3,9	4,4	5	5,5	6,7	7,8	8,9	10	11
95	1,6	2,1	2,6	3,1	3,7	4,2	4,7	5,2	6,3	7,4	8,4	9,4	10
100	1,5	2	2,5	3	3,5	4	4,5	5	6	7	8	9	10

With the help of charts you can define the consumption per hectare with a view to the size of chosen nozzle inserts, operating pressure, driving speed, and interlinear distance in the plantation, or you can define the size of nozzle inserts according to your requirements.

CHART 3: Flows of ceramic nozzle inserts LECHLER-TR (l/min)

NOTE: NOZZLE FLOWS ARE ALWAYS EQUAL FOR THE SAME LABEL COLOURS OF DIFFERENT TYPES (ST, LU, AD, ID, TR...), AND DIFFERENT NOZZLE MATERIALS.

CATALOGUE NO.	NOZZLE INSERT LABEL	NOZZLE INSERT COLOUR	WORKING PRESSURE (bar)																		
			2	3	4	5	6	7	8	9	10	11	12	13	14	15	16	17	18	19	20
019.48.068	TR 80-0067	BLACK	0,22	0,27	0,31	0,35	0,38	0,41	0,44	0,47	0,49	0,52	0,54	0,56	0,58	0,60	0,62	0,64	0,66	0,68	0,70
019.48.069	TR 80-01	OCHRE	0,32	0,39	0,45	0,51	0,55	0,60	0,64	0,68	0,72	0,75	0,78	0,82	0,85	0,88	0,91	0,93	0,96	0,99	1,01
019.48.070	TR 80-015	GREEN	0,48	0,59	0,68	0,76	0,83	0,90	0,96	1,02	1,07	1,13	1,18	1,22	1,27	1,31	1,36	1,40	1,44	1,48	1,52
019.48.071	TR 80-02	YELLOW	0,65	0,80	0,92	1,03	1,13	1,22	1,30	1,38	1,45	1,52	1,59	1,66	1,72	1,78	1,84	1,90	1,95	2,00	2,06
019.48.072	TR 80-03	BLUE	0,97	1,19	1,37	1,53	1,68	1,81	1,94	2,06	2,17	2,27	2,38	2,47	2,57	2,66	2,74	2,83	2,91	2,99	3,07
019.48.073	TR 80-04	RED	1,28	1,57	1,81	2,02	2,22	2,39	2,56	2,72	2,86	3,00	3,14	3,26	3,39	3,51	3,62	3,73	3,84	3,95	4,05
019.48.074	TR 80-05	BROWN	1,61	1,97	2,28	2,55	2,79	3,01	3,22	3,42	3,60	3,78	3,94	4,10	4,26	4,41	4,55	4,69	4,83	4,96	5,09

20.2 DIFFERENT CALCULATIONS

Water consumption per hectare can be read from the charts or calculated from the following equation:



The required nozzle insert flow for a particular per hectare consumption and operating speed can be calculated from the following equation:



Tractor's speed can best be checked by driving through the particular measured distance and measure the time spent for this:



Example No. 1:

There are 10 pieces of TR-OCHRE nozzle inserts incorporated in the sprayer, working pressure is set at 11 bar, interlinear distance in an orchard is 3.6 m, driving speed is 4.2 km/h.

What is the consumption per hectare?

Chart 1 shows that the required time for spraying per hectare is 40 min.

Chart 3 shows that OCHRE nozzle insert flow at a working pressure of 11 bar is 0.75 l/min.

Charts 2 shows that in 40 minutes and at a consumption of 7.5 l/min (for 10 nozzle inserts) 300 l/ha are consumed.

Example No. 2:

The desired spraying consumption is 300 l/ha, interlinear distance is 3.8 m, driving speed is 5.2 km/h. There are 10 nozzles open. What kind of inserts must be used and what is the required operating pressure for spraying?

Chart 1 shows that in our case the driving time for spraying per hectare is 30 min. According to chart 2, for this driving time and consumption of 300 l/ha the required aggregate flow is 10 l/min, or 1 l/min through one nozzle. In chart 3 we choose a corresponding nozzle insert, for our case it is GREEN for operating pressure at 9 bar, and OCHRE for operating pressure at 20 bar.

20.3 SOME RECOMMENDATIONS

- **Working Speed**

Spraying is usually done at tractor's speed of 3-6 km/h. The speed must be adjusted to the terrain configuration, but especially to the fan capacity. Too high working speed at a lower fan capacity can greatly reduce effects and spraying quality.

- **Engine Rotations**

For a quality sprayer's operation choose a gear at which you will be able to reach the operating speed at higher engine rotations (approx. 500 rotat./min on the tractor connection shaft). Only thus you will enable an adequate fan and pump capacities.

- **Water Consumption**

Water consumption at spraying in fruit-growing and viticulture widely ranges from 100 to 1500 l/ha. Lately, a lower consumption ranging from 100 to 300 l/ha is being introduced more and more due to lower costs. With such lower consumptions even more attention must be paid to preparing the machine for work, therefore it must have a quality equipment, quality nozzles, pressure filters, air rectifiers, and also it must enable a quality mixing process during operation. At a lower water consumption, the quantity of spray agent used per hectare must stay the same, which means that the spray agent concentration must be increased for as much as the water quantity has been reduced.

